



Servend®

ICE & BEVERAGE DISPENSERS



- Ice/Beverage • Specialty
- Drop-in • Counter Electric • Ice
- Beverage Valves • Cup Dispensers

Leader in Ice & Beverage Dispensers

Servend is a leading brand of ice and beverage dispensing equipment for the foodservice industry. Servend grew from a small manufacturing facility in the early 1980's where three employees spent one day building a single ice/beverage unit, to a 150,000 square foot of world class manufacturing and research facility area employing over 200 employees who build hundreds of units per day that are distributed throughout the world. Servend revolutionized the ice dispensing industry with innovations such as the patented "U-Shape" bin liner and "paddle wheel"



that maximizes ice storage, ice delivery and efficiency, and the "rocking chute" ice dispense mechanism which helps eliminate ice waste and spillage. Additional innovations include a manual-fill area for top-mounted ice machine applications, giant lightbox merchandisers for better graphic display, and hard-plumbed drink lines to significantly reduce leak points. The Servend product line includes ice, ice/beverage and juice countertop dispensers, drop-in and countertop electric beverage dispensers, ice chests, and numerous dispenser accessories.

Warranty



Servend provides a parts-and-labor warranty to repair or replace any defective part or assembly under normal use and care. For complete details, refer to the warranty statements that accompany our products.

Dispensers

- 2-year limited parts warranty
- 1-year limited labor warranty

Website



Visit us at

www.manitowocbeverage.com

Servend's website is an informative and interactive site that is continually updated. Some of the navigation pathways include; Product Sizing Guide, Sales and Service Locator, Sales and Service Literature Downloads, Trade Show Calendar, What's New, and additional links which help educate the visitor on the many facets associated with the selection of a beverage dispensing system.

Listings



Servend 2100 Future Drive • Sellersburg, IN 47172, USA
 Ph: 812-246-7000 • Fax: 812-246-7024
 Visit us online at www.manitowocbeverage.com

Servend is manufactured by ManitoWoc Beverage is a part of The ManitoWoc Company, Inc.

ISO



Certification guarantees internal control of the company's quality system and ensures consistency in every process. In addition, continuous improvement and corrective action requirements assure that the company meets customer's needs and delivers the highest quality product at the most cost effective price. Servend's registration is applicable under Quality System Standard 9001, the most comprehensive standard in the international community and it includes the design, manufacture and support of all products.





The Servend Product Line Includes:

Ice/Beverage



SV Series	6
SV200/250 Selectable icepic® Ice Crusher	6
MDH 302/402	8
MDH 302/402 icepic® Ice Crusher	8
FLAV'R PIC™	10
SV250 quickdraw™	12

Specialty



Flavor Magic™	13
FlexTower™	14
CT Series Tower	15
Flavor Shot Tower	16
4-in-1 Non-carb Tower	17

Drop-in



DI 1522/2323	18
Ice Chests	18
CS 1522/2323 Stands	18

Counter Electric Beverage



CEV	20
CEVj	21

Ice



S Series	22
M 45/90	23

Beverage Valves



424	24
464GP	25

Cup Dispensers



	26
--	----

Innovative Beverage Solutions

Door lock eliminates "ghost ice" dispensing

Advanced rocking chute moves with cup for reduced ice spillage



Durable ice door

Convenient "push button" / "push lever" conversion

Servend's innovative rocking chute door mechanism has a simple, non electrical injection molded design.

- 60% fewer parts than industry norm – no solenoids, springs, or counter weights to fail.
- On-site "push button" / "push lever" conversion.
- Reduces equipment and parts inventory.
- Reduces ice waste and build-up of ice in drain pan.
- Eliminates "ghost ice" dispensing.
- Reduces "in-flight" ice and ice spillage.

Patented Rocking Chute™ Ice Dispense

Patented Paddle-wheel Design

Patented paddle-wheel design maximizes ice storage, delivery, and efficiency and enables all potable ice to be dispensed.

"Hard Plumbed" drink lines enhance beverage cooling, eliminates up to 35 potential leaks and ensures cold drinks

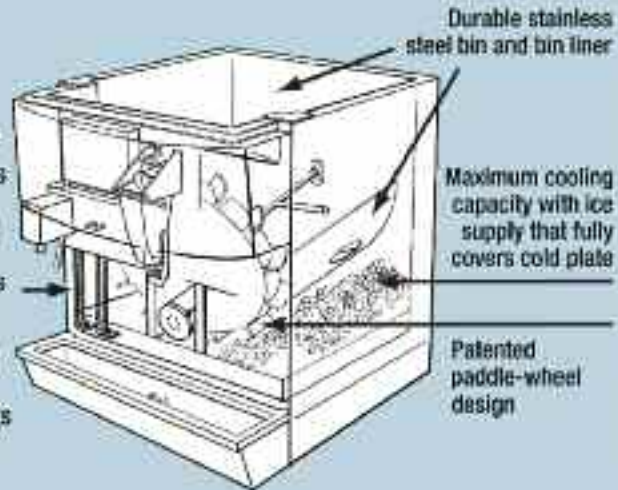

Patented iCepic™ Integrated Ice Crusher

Industry's only built-in ice crusher provides two types of ice (cube and crushed) from a single ice maker/ice dispenser combination.

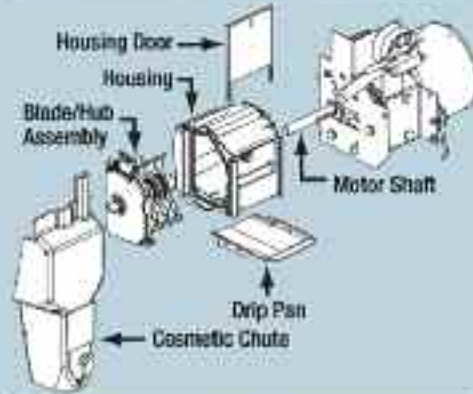

Patented Flexible Beverage Manifold

Flex manifold makes carbonated or non-carbonated flavor changes possible in minutes. Great for seasonal promotions!



Take a Closer Look at How Servend's Patented Features & Advanced Technologies Make Servend the Right Choice for You

Features of Servend's SV Series Ice/Beverage Dispensers



Optional top-mounted Manitowoc ice beverage ice machine offers enhanced cleanability and improved sanitation procedures for the ice storage area.

Accessible front bin extension allows for easier manual ice filling.

Flomatic 464 beverage valves improve drink quality and presentation. Fewer parts simplify cleaning.

Front serviceability of all major components.

Large "attention grabbing" fountain graphics.

Maximum beverage cooling, "Hard Plumbed" syrup and water lines.

Durable stainless steel construction exterior, bin and bin liner.

Patented technology Rocking Chute™ ice dispense reduces ice spillage.

Flex Manifold makes carbonated or non-carbonated flavor changes possible in minutes.

SV-250 Ice/Beverage Dispenser with Manitowoc IB ice machine

Features of Servend's Drop-In Series Beverage Dispensers



Dual-view merchandiser with high impact graphics.

High capacity ice storage. Large amount of ice storage - 60 lbs. (27.2 kgs.), 80 lbs. (36.4 kgs.) and 100 lbs. (45.5 kgs.).

Accessible splash panel, drain pan, and ice bin door can be easily removed without tools.

Quick, easy install cold plate inlets and drain connections simplify pre-plumbing and installation.



Flex Manifold makes carbonated or non-carbonated flavor changes possible in minutes.

DI-2323 Drop-In Beverage Dispenser

SV-150 • SV-175 • SV-200 • SV-250 Ice/Beverage Dispensers

Servend's new SV Series features a no-hassle one-piece structural base, recessed cold plate inlets for more line space behind the splash panel, and a modular design; all resulting in a more durable machine dispensing consistent, quality drinks.



*SV-250
Up to 250 lbs. (114
kgs.) ice storage
capacity
8 or 10 valves
30" (76.20 cm) wide*



*SV-200
Up to 200 lbs. (91 kgs.)
ice storage capacity
8 or 10 valves
30" (76.20 cm) wide*



*SV-175
Up to 175 lbs. (80 kgs.)
ice storage capacity
8 valves
25" (63.50 cm) wide*



*SV-150
Up to 150 lbs. (68 kgs.)
ice storage capacity
6 valves
23" (58.42 cm) wide*

Specifications

Standard Features

Ice Storage Capacity

Electrical Requirements

Number of Valves

Ice Machine Compatibility

Options

SV-150	SV-175	SV-200	SV-250
Lighted merchandiser, Quench graphics, key switch, leg kit, and drain kit.			
Up to 150 lbs. / 68 kgs.	Up to 175 lbs. / 80 kgs.	Up to 200 lbs. / 91 kgs.	Up to 250 lbs. / 114 kgs.
		Dispenser: 120V/60Hz/2.8FLA. 220V/50Hz/1 also available.	
6	8	8 or 10	
Manual fill or top-mount with compatible ice machines. Contact factory for adapter kit requirements for top-mounted ice machine applications.			

Flomatic 464 beverage valves. Both 424 and 464 available in sanitary lever, push button, portion control, and autofill valve. Other valves available. Contact MBE for details. Other options: regulators, installation kits, and side splash panels.

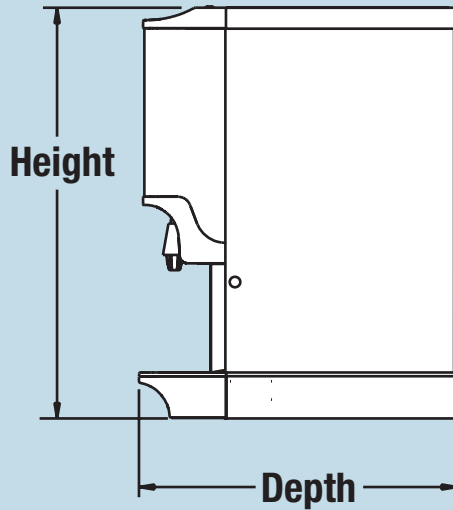
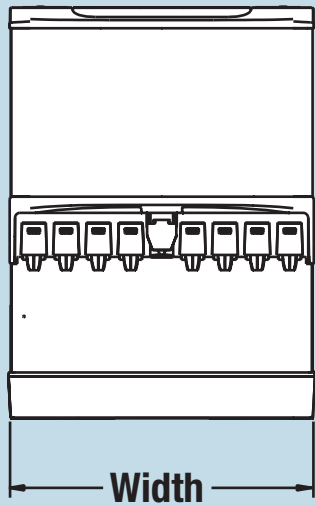

Unit	Width	Depth	Height
SV-150	23.00"	31.13"	34.88"
	58.42 cm	79.07 cm	88.60 cm
SV-175	25.00"	31.13"	34.88"
	63.50 cm	79.07 cm	88.60 cm
SV-200	30.00"	31.13"	34.88"
	76.20 cm	79.07 cm	88.60 cm
SV-250	30.00"	31.16"	40.88"
	76.20 cm	79.15 cm	103.82 cm

*Height dimension without full lid.
Add 0.50" (1.27 cm) for full lid.

SV200 • SV250 Selectable Ice/Beverage Dispensers



Servend's patented icepic™ feature is the industry's only built-in ice crusher providing selectable crushed and cubed types of ice from a single ice maker/ice-beverage dispenser combination.



*SV-200 Selectable
Up to 200 lbs.
(91 kgs.) ice
storage capacity
8 or 10 valves
30" wide
(76.20 cm)*

*SV-250 Selectable
Up to 250 lbs.
(114 kgs.) ice
storage capacity
8 or 10 valves
30" wide
(76.20 cm)*



MDH-302 • MDH-402 Countertop Ice/Beverage Dispensers

Servend's MDH Series features durable stainless steel ice bin and exterior construction and provides up to 20 valves with 400 lbs. (182 kgs.) of ice storage for your highest volume accounts.

MDH-302



MDH-402



MDH-302



MDH-402



MDH-302 • MDH-402 with icepic Integrated Crusher

Industry's only built-in ice crusher provides two types of ice (cubed and crushed) from a single ice maker/ice dispenser combination. Increased beverage cooling efficiency vs. nugget-style ice. Saves: 25% on equipment acquisitions, 30% on equipment installation, and 45% on maintenance.



Specifications

	<i>MDH-302</i>	<i>MDH-402</i>
Standard Features	Key Switch, Drain Kits, 12.00" tall lighted merchandiser, timed agitation, Flomatic 424 Beverage Valves	
Ice Storage Capacity	Up to 300 lbs. / 136 kgs.	Up to 400 lbs. / 181 kgs.
Electrical Requirements	Dispenser: 120V/60Hz/3.5FLA	
Ice Machine Compatibility	Front or side manual fill or top mount with compatible ice machine. Top mounted ice machines may reduce storage capacity. Contact distributor for baffle and ice maker lid requirements for top mounted ice machine applications.	Front or side manual fill or top mount with compatible ice machine. Top mounted ice machines may reduce storage capacity. Contact distributor for baffle and ice maker lid requirements for top mounted ice machine applications.
Graphic Area Dimensions	Visual area 12T: 41.75" W x 10.00" H / 106.05 W x 25.40 H (cm) 24T: 41.62" W x 22.88" H / 105.71 W x 58.12 H (cm) 34T: 41.88" W x 33.19" H / 106.38 W x 84.30 H (cm)	Visual area 12T: 59.13" W x 10.38" H / 150.19 W x 26.37 H (cm) 24T: 59.13" W x 23.19" H / 150.19 W x 58.90 H (cm) 34T: 59.13" W x 32.81" H / 150.19 W x 83.34 H (cm)
Options	Other options include; water lever, carbonator, regulator and installation kits. Ice machine adaptor kits, 24.00" (60.96 cm) and 34.00" (86.36 cm) extended merchandiser, black merchandiser and splash panel.	

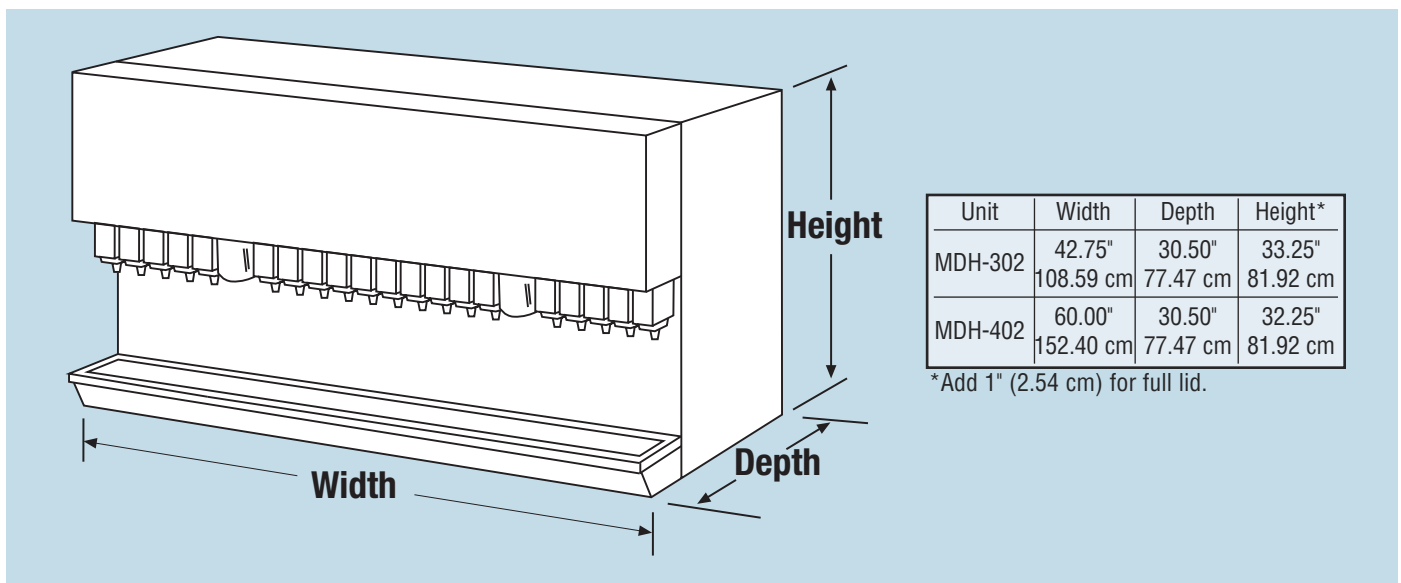

Unit	Width	Depth	Height*
MDH-302	42.75"	30.50"	33.25"
	108.59 cm	77.47 cm	81.92 cm
MDH-402	60.00"	30.50"	32.25"
	152.40 cm	77.47 cm	81.92 cm

*Add 1" (2.54 cm) for full lid.

FLAV'R PIC™ Multi-flavor Ice/Beverage Dispenser with Selectable Ice



Servend's new Flav'RPic ice/beverage dispenser gives your customer multiple options to customize their drink to their taste...16 beverage selections, up to 8 flavor enhancements and a choice of cube or crushed ice. Beverage options that customers appreciate and drive repeat business. All in a 30" footprint which maximizes use of counter space while providing 250 lbs. of ice storage.



FRP-250 Ice/Beverage Dispenser with IB800 Ice Machine

16 carbonated or non-carbonated beverage selections and a choice of 4 to 8 flavor enhancements—imagine the beverage combination possibilities.

Industry's only built-in ice crusher provides two types of ice (cubed and crushed) from a single ice maker/ice dispenser combination. One ice/beverage dispenser reduces your equipment expense, installation costs, and maintenance.



Specifications

Standard Features	Selectable icepic® feature, internal carbonation, lighted merchandiser, Flav'pic graphics, key switch, and drain kit.
Approximate Shipping Weight	378 lbs. / 172 kgs.
Approx. Countertop Weight (w/o ice)	343 lbs. / 156 kgs.
Ice Storage Capacity	Up to 250 lbs. / 114 kgs.
Electrical Requirements	Dispenser: 120V/60Hz/3.0FLA
Drain	Single 0.75 (1.91 cm) PVC (N.P.T.) drain fitting extends from drain pan. Dispenser can be drained from the bottom or back of unit.
Number of Valves	16 flavor capable (all syrups chilled) with 4 dispense points, 4 or 8 flavor shots/enhancements, with 2 dispense points.
Ice Machine Compatibility	Manual fill or top-mount with compatible ice machines. Contact factory for adapter kit requirements for top-mounted ice machine applications.
Manifold	Carb/Non-carb flexibility across all dispense points.
Options	Dispenser also available with cube only dispense options. Extended front splash panel, side splash panels, installation and backroom packages/kits.

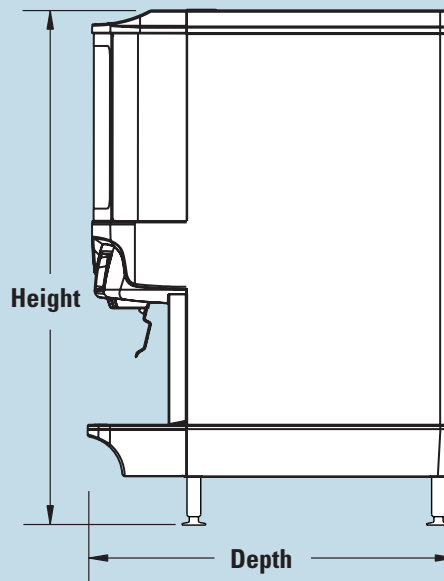
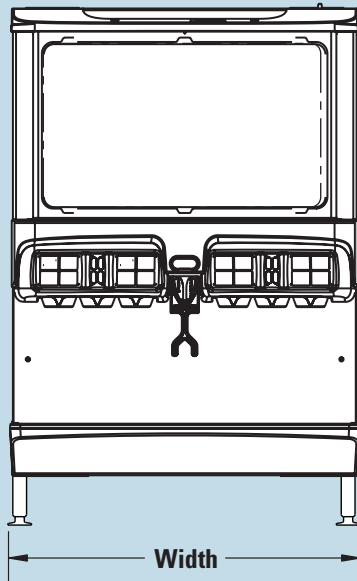

Unit	Width	Depth	Height*
FRP-250	30.00"	31.13"	40.88"
	76.20 cm	79.07 cm	103.80 cm

*Height dimension without full lid.
Add .050" (1.27 cm) for full lid.

Cup Dispensers



Volumetric-ice, portion control dispenser features one-touch, portion controlled ice dispense to increase your speed of service. Concave cup locator provides easy ice dispense positioning. Visual graphic display eases programming and diagnostics.

Specifications

Standard Features	Quickdraw volumetric-ice portioning system, integrated lid/straw holder, key switch, leg kit and drain kit.
Ice Storage Capacity	Up to 250 lbs. / 114 kgs.
Electrical Requirements	Dispenser: 120V/60Hz/2.8FLA. 220V/50Hz/1 also available.
Valves	8 auto-fill valves standard (other valve options available)
Ice Machine Compatibility	Manual fill or top-mount with compatible ice machines. Contact MBE for adapter kit requirements for top-mounted ice machine applications.
Options	Side splash guards (used for counter integrated drain rail).

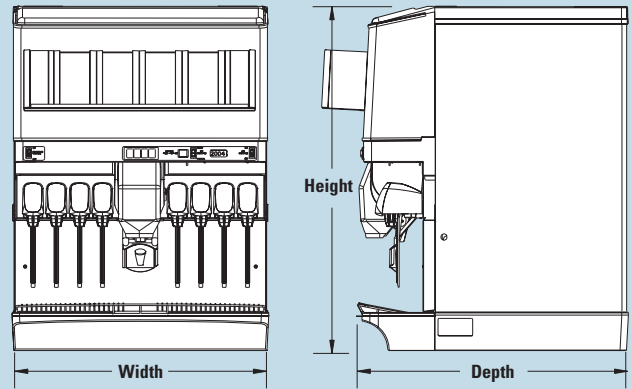

Unit	Width	Depth	Height*
SV-250QD	30.00" 76.20 cm	31.16" 79.15 cm	40.88" 103.82 cm

*Height includes lid.

Specifications

Standard Features	Portion control through adjustable dispense time, built-in dispense counter to track individual flavor sales, POP static cling instruction sheet, easy-to-install pre-assembled valve/control board module.
Flavor Magic Module Kit Contents	Switch cover with nozzle, ice chute bracket, cover mounting bracket, internal nozzle tubing mount, control board and valve solenoid assembly.
Back Room Kit Contents	BIB rack, BIB syrup pumps (1 for each flavor), low pressure CO2 regulator (0-100 PSI), 50 feet of bundled tubing (1 tube for each flavor)
BIB Rack Dimensions W x H x D	1 X 3 rack: 20" x 36" x 19"; 1 X 4 rack: 20" x 48" x 19"; 2 X 3 rack: 32" x 36" x 19"; 2 X 4 rack: 32" x 48" x 19"
Electrical	24VAC, 0.5 AMP, powered by existing valve transformer on dispenser
Flavors Dispensed	3 or 4 per module
Flow Rate	Variable, 0.5 oz/sec nominal
Dispense Time	0.2 - 10 seconds, adjustable in 0.2 second increments
Inlet Pressure Range	10 - 40 PSI

Flavor Magic™ Drink Enhancement System



Flomatic's Flavor Magic™ Drink Enhancement System allows you to offer your fountain beverage customers more flavor choices without using any additional counter space.

FlexTower™



FlexTower™ multi-flavor beverage dispenser capitalizes on current flavor enhancement trend with customized fountain flavors and products. Small footprint maximizes valuable counterspace. Dispenses either all non-carbonated post-mix beverages or a combination of beverages and flavor enhancements. Backlighted merchandiser and flashing keypad lights create visual appeal.

Specifications

	FT-8	FT-12	FT-16
Standard Features	Lighted merchandiser, flashing programmable touchpad LED's; integrated drain pan; removable splash shield.		
Electrical Requirements	120 Volts/60Hz/2.5 FLA		
Options	Servend Ice Beverage dispenser cooling coil options and remote refrigeration cooling options available.		

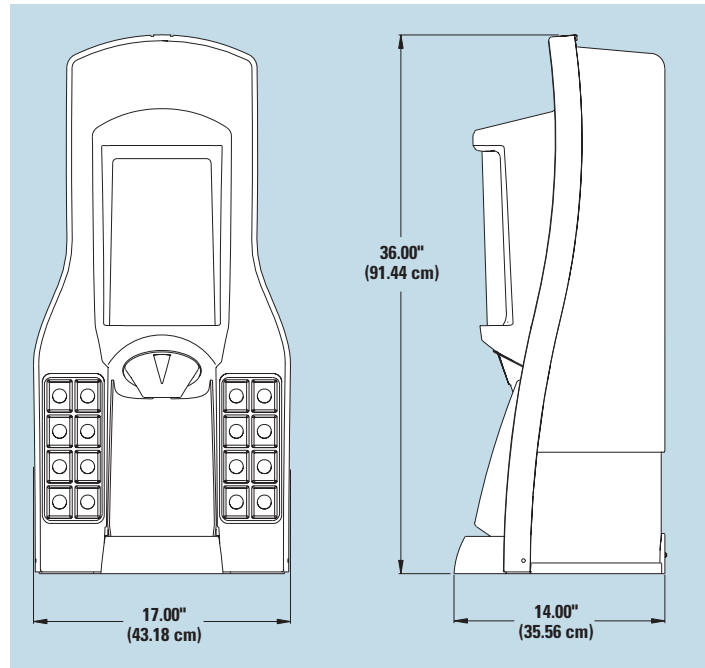

Specifications

	CT-6	CT-8
Standard Features	Flomatic 464 GP beverage valves. Lighted dual-view merchandiser, "Quench Your Thirst" graphics and key switch.	
Electrical Requirements	120V/60Hz / 2.4 FLA	120V/60Hz / 3.2 FLA
Options	Drop-in lightbox, splash guards and other beverage valves available.	

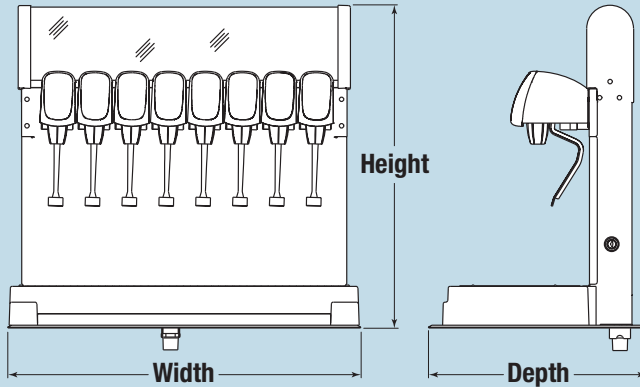

Unit	Width	Depth	Height
CT-6	17"	14.25"	22.50"
	43.18 cm	36.19 cm	57.15 cm
CT-8	25"	15.50"	22.85"
	63.50 cm	39.37 cm	58.04 cm

CT Series Countertop Tower



CT Series countertop tower allows easy addition of fountain beverages to limited-space applications. Lighted, dual-view merchandiser promotes sales. Tower is perfect for individual specialty beverage applications such as non-carbonated drinks. Stainless steel construction makes this unit durable, attractive, and easy to clean.

Flavor Shot Tower



Catch the current trend in beverage dispensing—customized fountain flavors and products. Compact size of Flavor Shot Tower works great in limited space areas, providing multiple placement opportunities, and simplifying integration with current fountain equipment. Non-tip base design for either permanent or portable installation. Push lever or push button option.

Specifications

Dimensions	7.19" W x 8.94" D x 17.70" H 18.26 W x 22.71 D x 44.96 H (cm)
Electrical Requirements	24V AC / 2.4 Amps / Remote mount
Cup Clearance	8.38" (21.29 cm)
Product Flavors	2
Material	Stainless steel
Valve Options	Valve type must be specified Push Lever Valve: Item #2703329 Push Button Valve: Item #2703315

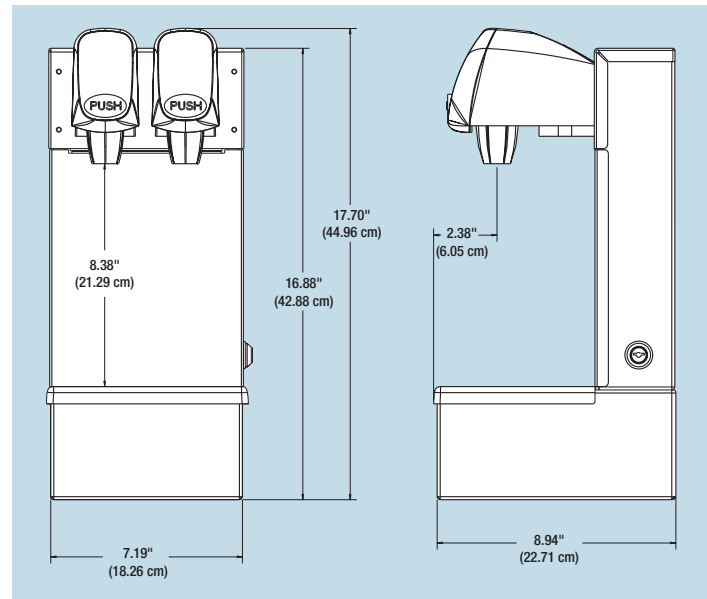

Specifications

Standard Features

2 McCann dual flavor valves (at 1.5-3 oz/sec), key switch, pre-installed water and syrup lines with 1/4" barbed fittings, 6' drain kit

Electrical Requirements

24V / 2.4 Amps

Cup Clearance

8.5" (21.6 cm)

Product Flavors

Two valve, four flavor push button or two valve, two flavor Flomatic lever valves

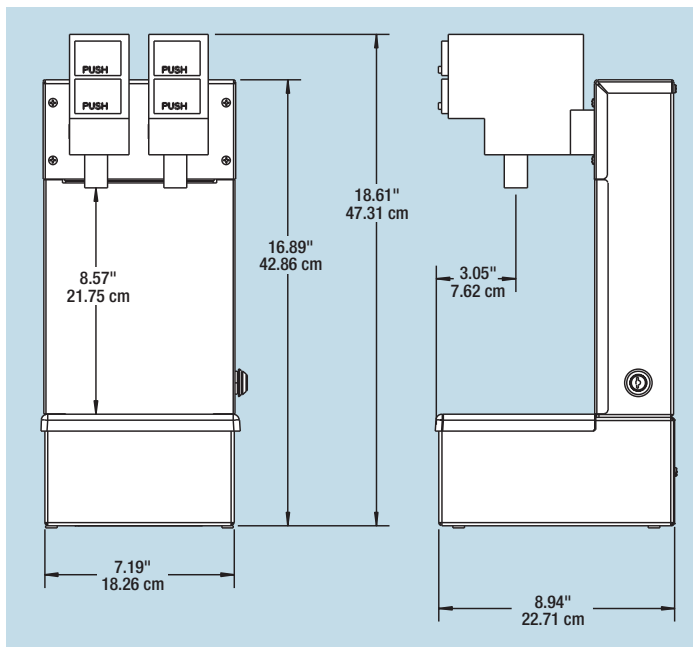

4-in-1 Non-carb Tower



Servend's two valve, four flavor beverage tower has a flexible design to provide convenient non-carb flavor options. The tower is also front and top serviceable. Two valve, two flavor option is also available. The tower's compact size works great in limited space areas, providing multiple placement opportunities.

Drop-in 1522/2323



DI-1522-6-SL



DI-2323-8-SL

Servend Drop-in Series offers maximum beverage cooling capacity in post-mix and pre-mix models. Quick, easy install cold plate inlets and drain connections simplify pre-plumbing and installation. Includes dual-view merchandiser light kit.

Drop-in Freestanding Ice Chests

Stainless steel drop-in cabinet stands are designed to provide versatility and flexibility in the placement of DI-1522, DI-2323, and DIL-2323 drop-in dispensers.



Freestanding Ice Chest



Drop-in Ice Chest

CS-1522 and CS-2323 Drop-in Stands

Stainless steel construction ensures long life and durability. Base cutouts simplify plumbing and electrical routing. Includes 6" (15.24 cm) leg set.



CS-2323 with DI-2323



CS-2323

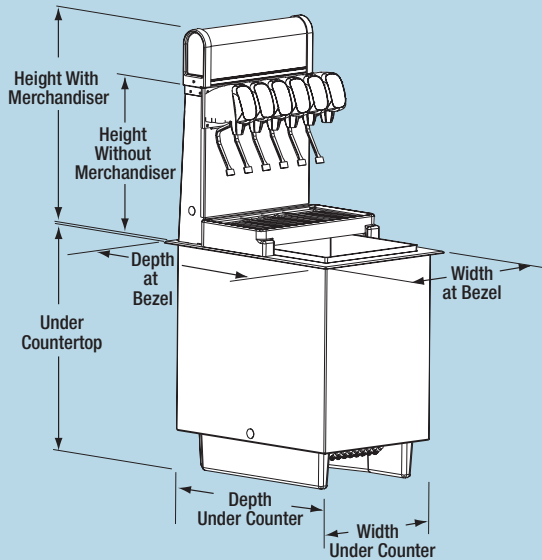

	DI-1522	DI-2323	DIL-2323
Width (Under counter)	15.00" 38.10 cm	23.00" 58.40 cm	23.00" 58.40 cm
Depth (Under counter)	22.00" 55.88 cm	23.00" 58.40 cm	23.00" 58.40 cm
Height without merchandiser	16.38" 41.61 cm	16.875" 42.86 cm	16.875" 42.86 cm
Height with merchandiser	22.38" 56.85 cm	22.75" 57.79 cm	22.75" 57.79 cm
Under countertop	23.54" 59.79 cm	18.00" 45.72 cm	21.50" 54.61 cm

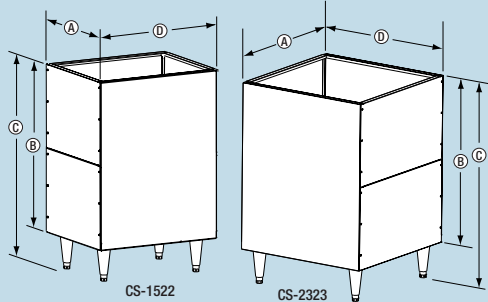

Unit	Width (A)	Depth (D)	Height (B)	Height (C)
CS-1522	17.25" 43.82 cm	24.25" 62.23 cm	30" 76.20 cm	36" 91.44 cm
CS-2323	25" 63.50 cm	25" 63.50 cm	30" 76.20 cm	36" 91.44 cm

Model 1522

60 Lb. (27.2 kg) Capacity

- A 24.29" (61.80 cm)
- B 17.25" (43.89 cm)
- C 14.25" (36.2 cm)
- D 22.00" (55.88 cm)
- E 15.00" (38.1 cm)

Model 2123

80 Lb. (36.28 kg) Capacity

- A 25.303" (64.38 cm)
- B 23.30" (59.29 cm)
- C 14.25" (36.2 cm)
- D 23.00" (58.42 cm)
- E 21.00" (53.34 cm)

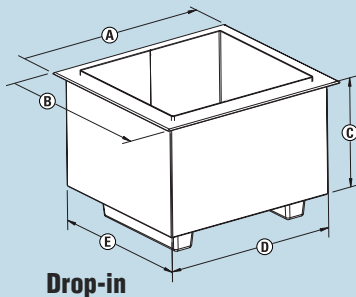

Drop-in

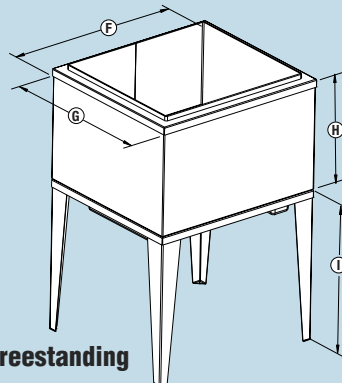

Freestanding

Model 1522

60 Lb. (27.2 kg) Capacity

- F 22.00" (55.88 cm)
- G 15.00" (38.1 cm)
- H 14.25" (36.2 cm)
- I 19.43" (49.45 cm)

Model 2123

80 Lb. (36.28 kg) Capacity

- F 23.00" (58.42 cm)
- G 21.00" (53.34 cm)
- H 14.25" (36.2 cm)
- I 19.43" (49.45 cm)

Specifications

	DI-1522	DI-2323	DIL-2323
Standard Features	Dual-view merchandiser, light kit. "Quench Your Thirst" graphics, key switch and drain kit.		
Ice Storage Capacity	Up to 65 lbs. 29 kgs.	Up to 77 lbs. 35 kgs.	Up to 97 lbs. 44.1 kgs.
Electrical Requirements	120V/60Hz/2.4FLA 220V/50Hz/1 also available	120V/60Hz/3.2FLA 220V/50Hz/1 also available	
Valves	Flomatic 464GP valves are available in sanitary lever, push button, portion control and automatic fill valves. Valve lockout switch on ice bin door available. Other valves available, contact factory for details.		
Options	Drop-in tower light box and splash guards.		

Specifications

	Model 1522 Freestanding or Drop-in Ice Chest
Ice Storage Capacity	60 lbs. / 27.27 kgs.
Cold Plate Fittings	3/8" (.95 cm) barbed (all)
Options	Available with seven circuit pre-mix cold plate; or eight circuit post-mix cold plate.

Specifications

	Model 2123 Freestanding or Drop-in Ice Chest
Ice Storage Capacity	80 lbs. / 36.36 kgs.
Cold Plate Fittings	3/8" (.95 cm) barbed (all)
Options	Available with seven circuit pre-mix cold plate; or with nine circuit post-mix cold plate.

CEV-30 • CEV-40 Post-mix Countertop Electric Dispensers



These post-mix countertop electric beverage dispensers offer maximum beverage cooling and customer-satisfying quality. The CEV Series is designed for quick, easy installation with front and top access to all major components.

Specifications

	<i>CEV-30 with internal carbonation system</i>	<i>CEV-40 with internal carbonation system</i>
Standard Features	Key switch, 3/8" (0.95 cm) barbed fittings, Flomatic 424 beverage valves, 4" (10.16 cm) adjustable legs, drain kits and integral cold carbonator	
Dimensions	CEV-30: 20.50" W x 28.16" D x 29.88" H 52.07 W x 71.54 D x 75.90 H (cm) CEV-40: 25.75" W x 28.16" D x 29.88" H 65.41 W x 71.54 D x 75.90 H (cm)	
Cup Clearance	11.77" (29.88 cm) height from grid to valve nozzle	
Exterior Body	Replaceable stainless steel panels	
Exterior Bonnet	Replaceable injection molded ABS plastic	
Water Tank	Polyethylene double wall rotocast, foam-filled	
Valves	6 Flomatic post-mix valves	8 Flomatic post-mix valves
Electrical Requirements	120V/60Hz/8.2FLA • 208-230V/60Hz/1 (export). Consult factory for options	
Ice Bank Control	Consolidated circuit board with pump and compressor protection capabilities	
Compressor	Tecumseh 1/3 HP	
Refrigerant	R-134a	
Refrigerant Deck	Independent lift out	
Carbonation Deck	Independent lift out	
Ice Bank Size (Nominal)	30-32 lbs. / 13.61-14.51 kgs.	
Options	Flomatic valves are available in sanitary lever, push button, and portion control. Other valves available. Lighted merchandiser, external carbonator configuration available.	

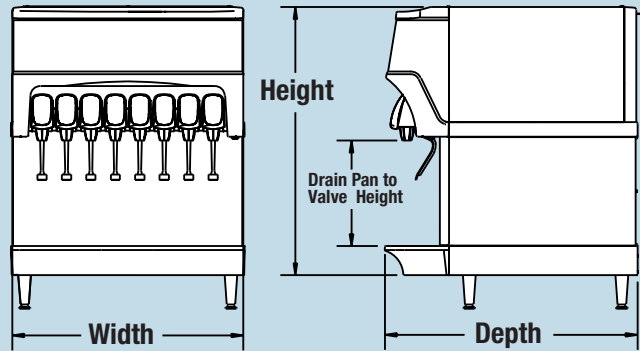

Unit	Width	Depth	Height	Drain Pan to Valve Height
CEV30	20.50" 52.07 cm	28.16" 71.54 cm	29.88" 75.90 cm	11.77" 29.88 cm
CEV40	25.75" 65.41 cm	28.16" 71.54 cm	29.88" 75.90 cm	11.77" 29.88 cm

Specifications

Standard Features	Key switch, 3/8" (0.95 cm) barbed fittings, Flomatic 424 juice valves, 4" (10.16 cm) black metal adjustable legs, drain kits and lighted merchandiser
Exterior Body	Replaceable stainless steel panels
Exterior Bonnet	Injection molded ABS plastic
Water Tank	Double wall rotocast, foamed in place polyethylene
Valves	6 Flomatic 424 post-mix juice valves
Electrical Requirements	120V/60Hz/1ph (domestic) • 208-230V/60Hz/1 (export) • 220-240V/50Hz/1ph (export)
Ice Bank Control	Consolidated circuit board with compressor protection capabilities
Compressor	Tecumseh 1/3 HP
Refrigerant	R-134a
Refrigerant Deck	Lift out
Ice Bank Size (Nominal)	30-32 lbs. / 13.61-14.51 kgs.
Options	Flomatic 424 valves are available in sanitary lever and push button.

CEVj-30 Post-mix Countertop Electric Juice Dispensers



The CEVj-30 post-mix countertop electric juice dispenser has enhanced design aesthetics with modular assembly including angled wrap-around illuminated merchandiser. Easy to service with quick access to air filter for cleaning. Also features easy slide on/off drain pan.

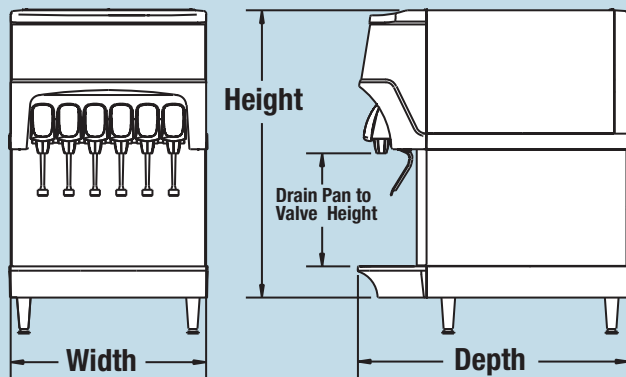

Unit	Width	Depth	Height	Drain Pan to Valve Height
CEV30	20.50" 52.07 cm	28.16" 71.54 cm	29.88" 75.90 cm	11.77" 29.88 cm

**S-150 • S-200 • S-250
Ice Dispensers**



S-150 with water valve option



S-200



S-250 with water valve option and Manitowoc S450 ice machine

Servend's S-Series ice dispensers feature a no-hassle one-piece structural base, strengthened drive train, and modular design, all resulting in a more durable ice dispenser. Surround view™ merchandiser with attractive “ice” graphics draws customer attention.

Specifications

	<i>S-150</i>	<i>S-200</i>	<i>S-250</i>
Standard Features	Lighted merchandiser, Ice graphics, leg kit, and drain kit.		
Ice Storage Capacity	Up to 150 lbs. 68 kgs.	Up to 200 lbs. 91 kgs.	Up to 250 lbs. 114 kgs.
Electrical Requirements	Dispenser: 120V/60Hz/2.8FLA. 220V/50Hz/1 also available.		
Ice Machine Compatibility	Manual fill or top-mount with compatible ice machines. Contact MBE for adapter kit requirements for top-mounted ice machine applications.		
Options	Flomatic water valve. Side splash panels. Flomatic 424 and 464 beverage valves, available in sanitary lever, push button, portion control and autofill valve.		

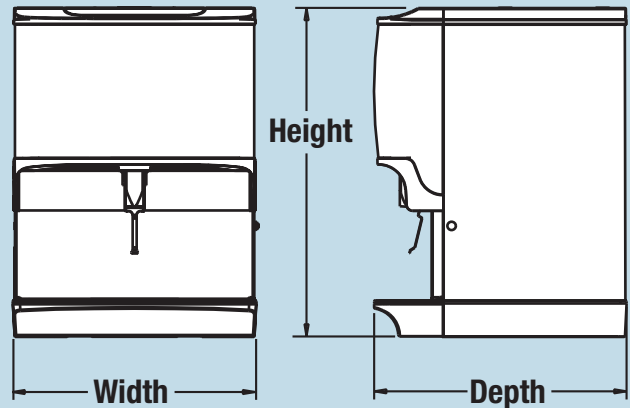

Unit	Width	Depth	Height
S-150	23.00" 58.42 cm	31.13" 79.07 cm	34.88" 88.6 cm
S-200	30.00" 76.2 cm	31.13" 79.07 cm	34.88" 88.6 cm
S-250	30.00" 76.2 cm	31.13" 79.07 cm	40.88" 103.8 cm

Height dimension without full lid.
Add .50" (1.27 cm) for full lid.

Specifications

	M-45	M-90
Standard Features	Stainless steel exterior cabinet with merchandiser and "Ice" sign, push lever ice dispense.	
Ice Storage Capacity	Up to 45 lbs. / 20 kgs.	Up to 90 lbs. / 41 kgs.
Electrical Requirements	120V/60Hz/2.5 FLA, 220V/50Hz/1 also available	
Ice Cube Compatibility	Dispenses any size cube ice up to one inch square and some compacted flake forms. Flake ice is not recommended.	
Service	Motor, drain, and electrical connections are front serviceable.	
Options	Lighted merchandiser, 4" (10.17 cm) leg kit, extended splash panel and push button ice dispense.	

M-45 and M-90 ice dispensers will not accommodate a top-mounted ice machine. Manual fill only. Beverage valves are not available on M-45 and M-90 ice dispensers.

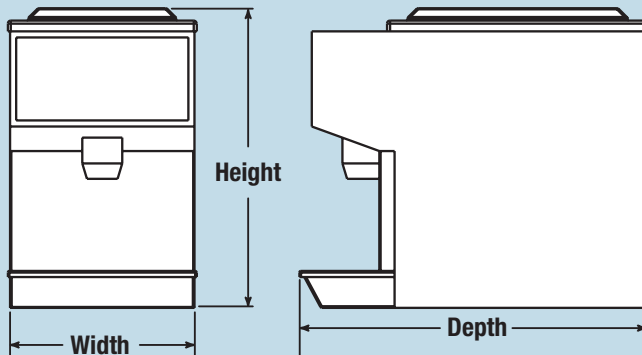

Unit	Width	Depth	Height
M-45	15.00" 38.10 cm	28.00" 71.10 cm	24.25" 61.60 cm
M-90	15.00" 38.10 cm	28.00" 71.10 cm	32.00" 81.30 cm

M-45 • M-90 Countertop Ice Dispensers



M-45



M-90

Servend's ice dispenser's simple design, upfront serviceability and quality construction, ensures long equipment life. Patented paddle-wheel ice dispenser technology maximizes counter space and allows more ice to be dispensed from the bin. Push lever or push button ice dispense available.

Cup Dispensers

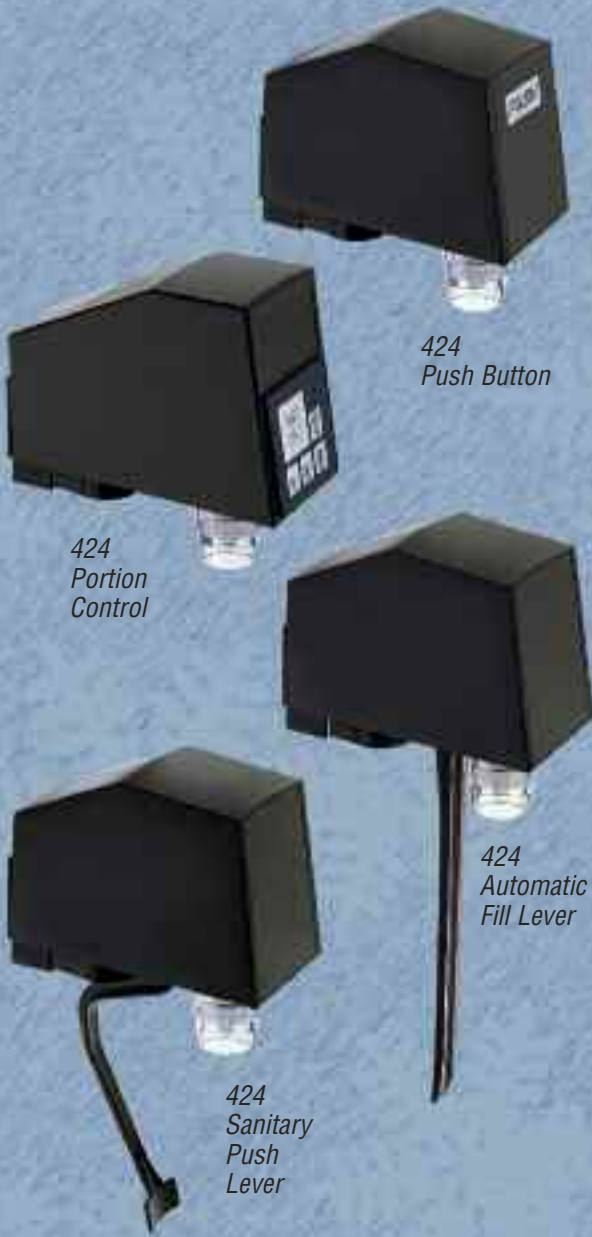

424
Push Button

424
Portion
Control

424
Automatic
Fill Lever

424
Sanitary
Push
Lever

**Proven Design Delivers
Consistent Drink Quality**

1.5 - 3.0 ounce per second flow rate

Specifications

Sanitary Push Lever

Model Number	424-CF-E36-1521
Dimensions	2.5" W x 4.5" D x 9" H 6.35 x 11.43 x 22.86 cm
Mounting Blocks	380-Q / 372-Q
Shipping	32 valves per box. Mounting blocks sold and packed separately.
Options	Add-a-Lever; field conversion options available for push button, portion control and automatic fill lever; manual option available.

Push Button

Model Number	424-CF-S36-1525
Dimensions	2.5" W x 4.5" D x 4.75" H 6.35 x 11.43 x 12.07 cm
Mounting Blocks	380-Q / 372-Q
Shipping	32 valves per box. Mounting blocks sold and packed separately.
Options	Add-a-Lever; field conversion options available for sanitary push lever, portion control and automatic fill lever.

Portion Control

Model Number	424-CF-P36-1500
Dimensions	2.5" W x 5" D x 5.125" H 6.35 x 12.7 x 13.02 cm
Mounting Blocks	380-Q / 372-Q
Shipping	32 valves per box. Mounting blocks sold and packed separately.
Options	Add-a-Lever; field conversion options available for sanitary push lever, push button, automatic fill lever.

Automatic Fill Lever

Model Number	424-CF-A36-1521
Dimensions	2.5" W x 4.5" D x 10.5" H 6.35 x 11.43 x 26.04 cm
Mounting Blocks	380-Q / 372-Q
Shipping	32 valves per box. Mounting blocks sold and packed separately.
Options	Add-a-Lever; field conversion options available for sanitary push lever, push button and portion control.

**Flomatic Valve Warranty
2-year parts only.**

Specifications

Sanitary Push Lever

Model Number

464-CF-E36-1621

Dimensions

2.5" W x 5.625" D x 9" H
6.35 x 11.49 x 22.86 cm

Mounting Blocks

380-Q

Shipping

32 valves per box.
Mounting blocks sold and packed separately.

Options

Add-a-Lever; field conversion options available for push button, portion control and automatic fill lever; manual option available.

Push Button

Model Number

464-CF-S36-1625

Dimensions

2.5" W x 5.625" D x 9" H
6.35 x 11.49 x 22.86 cm

Mounting Blocks

380-Q

Shipping

32 valves per box.
Mounting blocks sold and packed separately.

Options

Add-a-Lever; field conversion options available for sanitary push lever, portion control and automatic fill lever.

Portion Control

Model Number

464-CF-P36-1600

Dimensions

2.5" W x 5.625" D x 9" H
6.35 x 11.49 x 22.86 cm

Mounting Blocks

380-Q

Shipping

32 valves per box.
Mounting blocks sold and packed separately.

Options

Add-a-Lever; field conversion options available for sanitary push lever, push button, automatic fill lever.

Automatic Fill Lever

Model Number

464-CF-A36-1621

Dimensions

2.5" W x 5.625" D x 12.375" H
6.35 x 11.49 x 30.48 cm

Mounting Blocks

380-Q

Shipping

32 valves per box.
Mounting blocks sold and packed separately.

Options

Add-a-Lever; field conversion options available for sanitary push lever, push button and portion control.

464-GP Post-mix Valve



464-GP
Push Button



464-GP
Portion
Control



464-GP
Automatic
Fill Lever



464-GP
Sanitary
Push
Lever

**Global Performance For
All Dispensing Applications**

2.0 - 4.0 ounce per second flow rate

Cup Dispensers



Projecting a clean, high quality image is part of any successful foodservice program. Servend cup dispensers help keep your hot or cold drink serving area organized by giving a uniform appearance to the storage of cups and drink accessory items.

Stainless Steel & Black CD4U Cup Dispensers

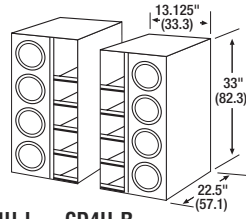

CD4U-L CD4U-R

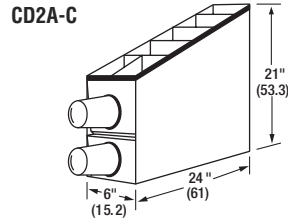

CD2A-C

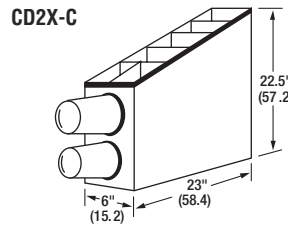

CD2X-C

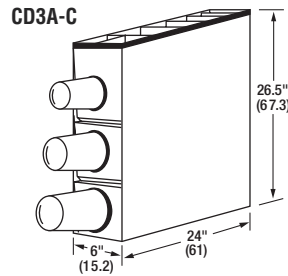

CD3A-C

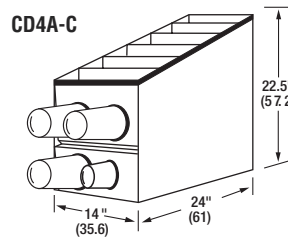

CD4A-C

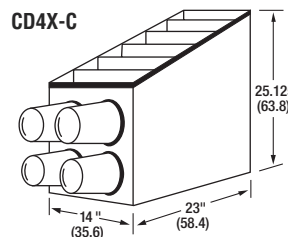

CD4X-C

Choose the Ice



Dice



Half Dice



Crushed



Nugget

THERE'S ONLY ONE "S"

SIMPLICITY

SAVINGS

SANITATION

SERVICEABILITY



Match Your Beverage Dispenser with a Manitowoc S-Series Ice Machine



Manitowoc's S-Series ice machines are the most technologically advanced ice machines in the market today. Innovations have been made in sanitation, energy savings, reduction in noise levels and ease of serviceability. No matter what your ice volume needs are, there's a Manitowoc machine that will get the job done. Manitowoc's line of commercial ice cube machines range in daily output from 45 lbs. (21 kgs.) up to 2,000 (908 kgs.) pounds. Choose air, water, or remote air-cooled condenser models producing dice, and half dice size ice cube. Visit our website at www.manitowocice.com to see why Manitowoc is America's number one selling ice machine.

www.manitowocice.com



High quality, innovative solutions that fulfill all your “cold-side” needs.
 Manitowoc Foodservice is comprised of eight brand names.
 For beverage products – Servend, Multiplex, and McCann's;
 for ice products – Manitowoc Ice;
 and for refrigeration products – Kolpak, McCall, Harford, and Koolaire.
 Visit us today at www.manitowocfoodservice.com



We are committed to protecting the environment and its resources. For up-to-date product data always view an electronic version on our web site.

3954E ©2009 Manitowoc 11/09 Continuing product improvement may necessitate change of specifications without notice.



MANITOWOC BEVERAGE
 2100 Future Drive
 Sellersburg, IN 47172, USA
 Ph: 812-246-7000 • Fax: 812-246-7024
 Visit us online at
www.manitowocbeverage.com

