

BUNN[®] ***DUAL***[®] ***SH*** ***1.50 & 1.75 GALLON***

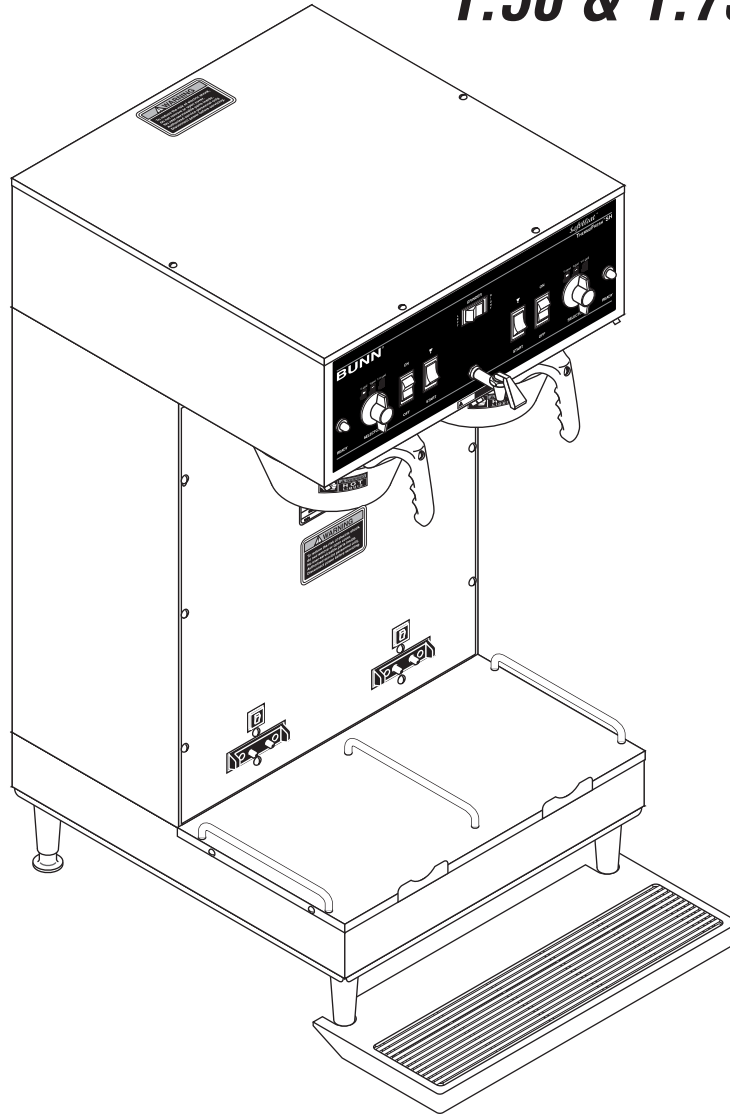

OPERATING & SERVICE MANUAL

BUNN-O-MATIC CORPORATION

POST OFFICE BOX 3227

SPRINGFIELD, ILLINOIS 62708-3227

PHONE: (217) 529-6601 FAX: (217) 529-6644

To ensure you have the latest revision of the manual or to obtain the illustrated parts catalog, please visit the Bunn-O-Matic website, at www.bunn.com. This is absolutely FREE, and the quickest way to obtain the latest catalog and manual updates. Contact Bunn-O-Matic Corporation at 1-800-286-6070 to obtain a paper copy of the required Illustrated Parts Catalog mailed via U.S. Postal Service.

BUNN-O-MATIC COMMERCIAL PRODUCT WARRANTY

Bunn-O-Matic Corp. ("BUNN") warrants equipment manufactured by it as follows:

- 1) All equipment other than as specified below: 2 years parts and 1 year labor.
- 2) Electronic circuit and/or control boards: parts and labor for 3 years.
- 3) Compressors on refrigeration equipment: 5 years parts and 1 year labor.
- 4) Grinding burrs on coffee grinding equipment to grind coffee to meet original factory screen sieve analysis: parts and labor for 3 years or 30,000 pounds of coffee, whichever comes first.

These warranty periods run from the date of installation BUNN warrants that the equipment manufactured by it will be commercially free of defects in material and workmanship existing at the time of manufacture and appearing within the applicable warranty period. This warranty does not apply to any equipment, component or part that was not manufactured by BUNN or that, in BUNN's judgment, has been affected by misuse, neglect, alteration, improper installation or operation, improper maintenance or repair, damage or casualty. This warranty is conditioned on the Buyer 1) giving BUNN prompt notice of any claim to be made under this warranty by telephone at (217) 529-6601 or by writing to Post Office Box 3227, Springfield, Illinois 62708-3227; 2) if requested by BUNN, shipping the defective equipment prepaid to an authorized BUNN service location; and 3) receiving prior authorization from BUNN that the defective equipment is under warranty.

THE FOREGOING WARRANTY IS EXCLUSIVE AND IS IN LIEU OF ANY OTHER WARRANTY, WRITTEN OR ORAL, EXPRESS OR IMPLIED, INCLUDING, BUT NOT LIMITED TO, ANY IMPLIED WARRANTY OF EITHER MERCHANTABILITY OR FITNESS FOR A PARTICULAR PURPOSE. The agents, dealers or employees of BUNN are not authorized to make modifications to this warranty or to make additional warranties that are binding on BUNN. Accordingly, statements by such individuals, whether oral or written, do not constitute warranties and should not be relied upon.

If BUNN determines in its sole discretion that the equipment does not conform to the warranty, BUNN, at its exclusive option while the equipment is under warranty, shall either 1) provide at no charge replacement parts and/or labor (during the applicable parts and labor warranty periods specified above) to repair the defective components, provided that this repair is done by a BUNN Authorized Service Representative; or 2) shall replace the equipment or refund the purchase price for the equipment.

THE BUYER'S REMEDY AGAINST BUNN FOR THE BREACH OF ANY OBLIGATION ARISING OUT OF THE SALE OF THIS EQUIPMENT, WHETHER DERIVED FROM WARRANTY OR OTHERWISE, SHALL BE LIMITED, AT BUNN'S SOLE OPTION AS SPECIFIED HEREIN, TO REPAIR, REPLACEMENT OR REFUND.

In no event shall BUNN be liable for any other damage or loss, including, but not limited to, lost profits, lost sales, loss of use of equipment, claims of Buyer's customers, cost of capital, cost of down time, cost of substitute equipment, facilities or services, or any other special, incidental or consequential damages.

BrewWISE, BUNN Gourmet Ice, BUNN Pour-O-Matic, BUNN, Bunn-OMatic, Bunn-O-Matic, BUNNlink, BUNNserve, BUNN Espresso, DBC, Dr. Brew, Dual, EasyClear, EasyGard, Easy Pour, FlavorGard, Gourmet Ice, Gourmet Juice, High Intensity, IMIX, Infusion Series, Legendary for Quality, The Mark of Quality in Beverage Equipment Worldwide, My Café, Power-Logic, Safety-Fresh, Single, Smart Funnel, Smart Hopper, Soft Heat, SplashGard, System III, ThermoFresh, AXIOM, Beverage Profit Calculator, Beverage Bar Creator, BrewLOGIC, BrewMETER, BrewWIZARD, BUNNSERVE, BUNNsource, Coffee At Its Best, Coffee Spot, Cool Froth, Digital Brewer Control, Earth-1st, Earth 1st, Earth First, Intellisteam, Nothing Brews Like a BUNN, Pouring Profits, Pulse Wave, Quality Beverage Equipment Worldwide, Scale-Pro, Signature Series, Silver Series, Smart Heat, SmartWAVE, Tea At Its Best, The Horizontal Red Line, Titan, Ultra, are either trademarks or registered trademarks of Bunn-O-Matic Corporation.

INTRODUCTION

This equipment will brew two 1/2 gallon, 1 gallon and 1-1/2 gallon or 1-3/4 gallon batches of coffee into awaiting servers at the push of a button. The brewer is also equipped with a hot water faucet for allied beverage use and is designed to interface with a BUNN® Grinder. The brewer is specifically designed for use with BUNN® 1-1/2 gallon or 1-3/4 gallon soft heat servers. It is only for indoor use on a sturdy counter or shelf.

USER NOTICES

The notices on this brewer should be kept in good condition. Replace unreadable or damaged labels.

00658.0000

00831.0000

37881.0000

00656.0000

03408.0004

39803.0000

03409.0004

20201.5600



00824.0000



00824.0001

ELECTRICAL REQUIREMENTS

WARNING - The brewer must be disconnected from the power source until specified in *Initial Set-Up*.

Refer to Data Plate on the Brewer, and local/national electrical codes to determine circuit requirements.

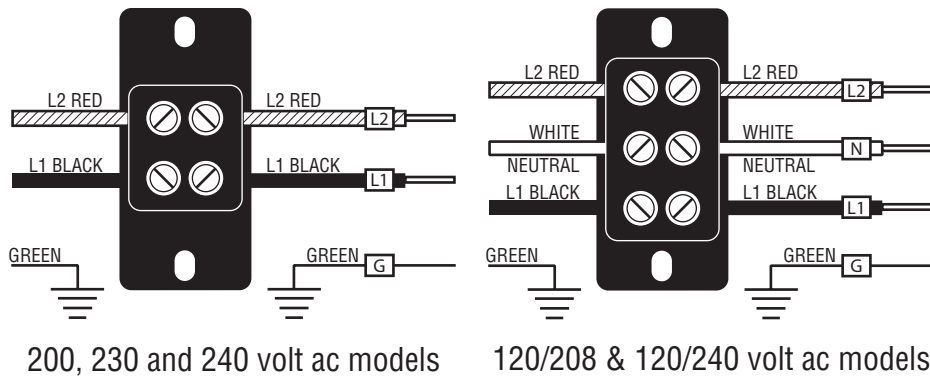

Note: This electrical service consists of 2 current carrying conductors (L1 and L2) and a separate conductor for earth ground.

Note: This electrical service consists of 3 current carrying conductors (Neutral, L1 and L2) and a separate conductor for earth ground.

Electrical Hook-Up

CAUTION – Improper electrical installation will damage electronic components. **Damage caused by incorrect electrical connections is not covered by warranty.**

1. An electrician must provide electrical service as specified in conformance with all local, state and federal electrical codes.
2. Using a voltmeter, check the voltage and color coding of each conductor at the electrical source.
3. Remove the front panel beneath the sprayhead and rotate the control thermostat knob fully counterclockwise to the “OFF” position.
4. Feed the cord through the strain relief and connect it to the terminal block.
5. Connect the brewer to the power source and verify the voltage at the terminal block before proceeding. Replace the front panel.
6. If plumbing is to be hooked up later be sure the brewer is disconnected from the power source. If plumbing has been hooked up, the brewer is ready for *Initial Set-Up*.

CE REQUIREMENTS

- This appliance must be installed in locations where it can be overseen by trained personnel.
- For proper operation, this appliance must be installed where the temperature is between 0°C to 35°C.
- Appliance shall not be tilted more than 10° for safe operation.
- An electrician must provide electrical service as specified in conformance with all local and national codes
- This appliance must not be cleaned by water jet
- This appliance is not intended for use by persons (including children) with reduced physical, sensory or mental capabilities, or lack of experience and knowledge, unless they have been given instructions concerning use of this appliance by a person responsible for its safety.
- If the power cord is ever damaged, it must be replaced by the manufacturer or authorized service personnel with a special cord available from the manufacturer or its authorized service personnel in order to avoid a hazard.

PLUMBING REQUIREMENTS

This brewer must be connected to a cold water system with operating pressure between 20 and 90 psi (138 and 620 kPa) from a 1/2" or larger supply line. A shut-off valve should be installed in the line before the brewer. Install a regulator in the line when pressure is greater than 90 psi (620 kPa) to reduce it to 50 psi (345 kPa). The water inlet fitting is 1/4" flare or female quick connect.

NOTE – Bunn-O-Matic recommends 1/4" copper tubing for installations of less than 25 feet and 3/8" for more than 25 feet from the 1/2" water supply line. A tight coil of copper tubing in the water line will facilitate moving the brewer to clean the countertop. Bunn-O-Matic does not recommend the use of a saddle valve to install the brewer. The size and shape of the hole made in the supply line by this type of device may restrict water flow.

This equipment must be installed to comply with the International Plumbing Code of the International Code Council and the Food Code Manual of the Food and Drug Administration (FDA). For models installed outside the U.S.A., you must comply with the applicable Plumbing/Sanitation Code for your area.

PLUMBING HOOK-UP

1. Flush the water line and securely attach it to the flare fitting or quick disconnect located on bottom of brewer.
2. Turn on the water supply.

INITIAL SET-UP

CAUTION – The brewer must be disconnected from the power source throughout the initial set-up, except when specified in the instructions.

1. Remove the front panel beneath the sprayhead. Rotate the control thermostat knob fully counterclockwise to the "OFF" position.
2. Connect the brewer to the power source. Water will begin flowing into the tank.
3. When water stops flowing into the tank, rotate the control thermostat knob fully clockwise to the "ON" position and replace the front panel.
4. Wait approximately twenty minutes for the water in the tank to heat to the proper temperature.
5. Place an empty server beneath either of the brew stations. Place its associated Selector switch in the desired position, the On/Off switch in the upper position and initiate a brew cycle.
6. Place the On/Off switch in the lower "OFF" position after water has stopped flowing from the funnel, and check the water volume in the server. It should be 64 oz (1/2 gallon), 128 oz (1 gallon), 196 oz (1-1/2 gallon) 224 oz (1-3/4 gallon) or adjust volume to your company specifications.
7. (A) If not, adjust the timer for that brew station as required. Refer to Adjusting Brew Volumes.
(B) If necessary adjust the needle valve to achieve desired water volume to be bypassed around the coffee filter in the funnel.

NOTE: To increase the water bypass turn the needle valve counterclockwise, to decrease the water bypass turn the needle valve clockwise. An adjustment of the needle valve will require a timer adjustment for volume of 1 gallon 1-1/2 gallon or 1-3/4 gallon.

8. Repeat step 7 until the proper water volume is achieved.
9. Repeat steps 5 through 8 for the other brew station.
10. The brewer is now ready for use in accordance with the coffee brewing instructions.

ADJUSTING BREW VOLUMES

CAUTION - Disconnect the power source from the brewer prior to the removal of any panel for the replacement or adjustment of any component.

NOTE: Prior to setting or modifying batch sizes, check that the brewer is connected to water supply, the tank is properly filled, and a funnel and server are in place.

1. **Modifying batch sizes.** To modify a batch volume, first check that the SET/LOCK switch is in the "SET" position on the circuit board.

ADJUSTING BREW VOLUMES (Cont.)

To increase a batch size. Press and hold the START or BREW switch until three clicks are heard. Release the switch (Failure to release the switch within two seconds after the third click causes the volume setting to be aborted and previous volume setting will remain in memory) and press it again one or more times. Each time the switch is pressed, two seconds are added to the brew time period. Allow the brew cycle to finish in order to verify that the desired volume has been achieved.

To decrease a batch size. Press and release the START or BREW switch once for every two-second interval to be removed from the total brew time period; then immediately press and hold down the START or BREW switch until three clicks are heard. Release the switch. (Failure to release the switch within two seconds after the third click causes the volume setting to be aborted and previous volume setting will remain in memory). Allow the brew cycle to finish in order to verify that the desired volume has been achieved.

- Setting batch sizes.** To set a batch volume, first check that the SET/LOCK switch is in the “SET” position on the circuit board. Press and hold the START or BREW switch until three distinct clicks are heard, and then release the switch. (Failure to release the switch within two seconds after the third click causes the volume setting to be aborted and previous volume setting will remain in memory). View the level of the liquid being dispensed. When the desired level is reached, turn the ON/OFF switch to “OFF” (lower). The brewer remembers this volume and will continue to brew batches of this size until the volume setting procedure is repeated.

NOTE: When brewing coffee, batch volumes will decrease due to absorption by the coffee grounds.

- Setting programming disable feature.** If it becomes necessary to prevent anyone from changing brew times once programmed, you can set the SET/LOCK switch to the “LOCK” position. This will prevent any programming to be done until switch is once again placed in the “SET” position.

OPERATING CONTROLS

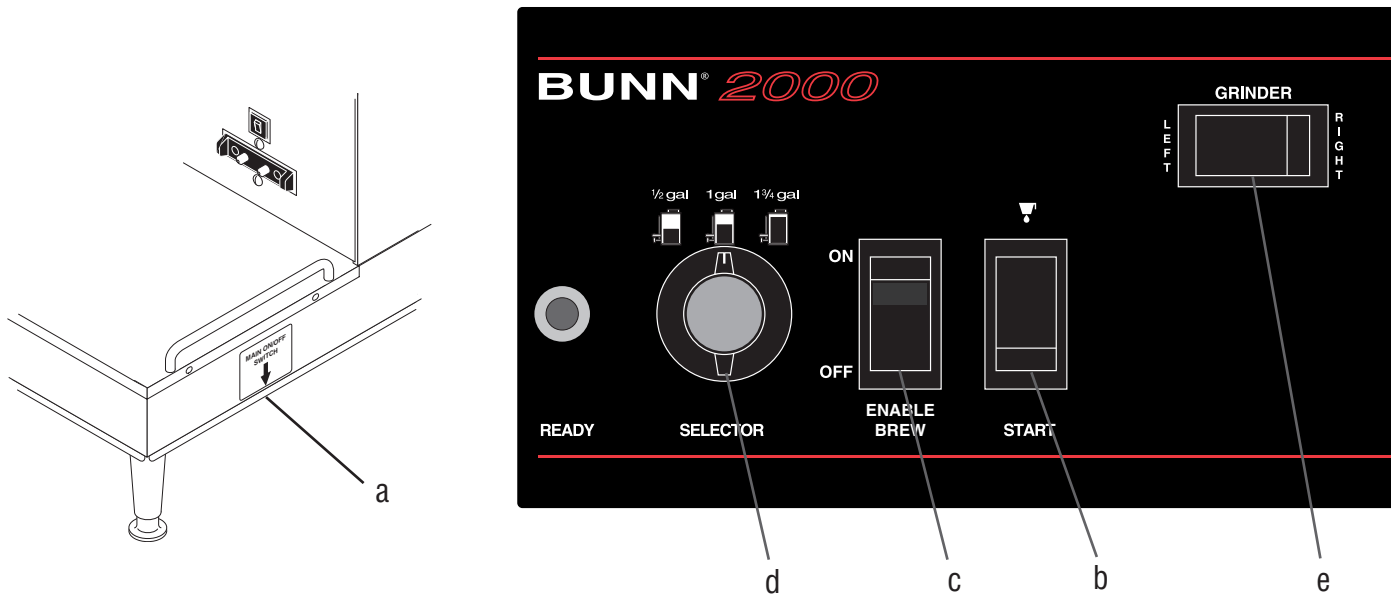

(a) MAIN ON/OFF SWITCH

This switch, located under the brewer behind the right front leg, turns power on and off to all components in the brewer.

(b) START SWITCH

Momentarily pressing and releasing this switch starts a brew cycle when the On/Off switch is in the lighted upper position.

NOTE: The On/Off switch must be in the lighted upper position to initiate and complete a brew cycle.

(c) ENABLE BREW (ON/OFF SWITCH)

Placing the switch in the unlighted lower position cuts power to the timer and stops brewing. Stopping a brew cycle after it has been started will not stop the flow of water from the funnel. Placing the switch in the lighted upper position supplies power to the timer and enables the brew circuit.

OPERATING CONTROLS (cont.)

(d) BREW SELECTOR SWITCH

Placing the switch in the 1/2 gallon, 1 gallon, 1-1/2 or 1-3/4 gallon position selects the amount of coffee to be brewed in subsequent brew cycles. Repositioning this switch after a brew cycle has been initiated does not change the brew batch in progress.

(e) GRINDER SELECTOR SWITCH

Pressing the right or left side of the switch selects the corresponding brew station to the grinder interface.

NOTE – The On/Off switch must be in the lighted upper position to initiate and complete a brew cycle.

COFFEE BREWING

1. Select the desired batch size.
2. Insert a BUNN filter into the funnel.
3. Pour the proper amount of fresh coffee into the filter and level the bed of grounds by gently shaking.
4. Slide the funnel into the funnel rails.
5. Place an empty server under the funnel.
6. Place the On/Off switch in the lighted upper position. Momentarily press and release the start switch.
7. When brewing is completed, simply discard the grounds and filter.

CLEANING

1. The use of a damp cloth rinsed in any mild, nonabrasive, liquid detergent is recommended for cleaning all surfaces on Bunn-O-Matic equipment.
2. Remove and clean the sprayhead. Use the pointed end of sprayhead cleaning tool (#38227.0000) to remove any mineral deposits from the sprayhead holes.
3. Insert the long end of sprayhead cleaning tool into the sprayhead fitting, and rotate several times to remove any mineral deposits from the fitting.
4. Insert the short end of sprayhead cleaning tool into the bypass fitting, and rotate several times to remove any mineral deposits from the fitting.

NOTE: In hard water areas, this may need to be done daily. It will help prevent liming problems in the brewer and takes less than a minute.

TROUBLESHOOTING

A troubleshooting guide is provided to suggest probable causes and remedies for the most likely problems encountered. If the problem remains after exhausting the troubleshooting steps, contact the Bunn-O-Matic Technical Service Department.

- Inspection, testing, and repair of electrical equipment should be performed only by qualified service personnel.
- All electronic components have 120 - 240 volt ac and low voltage dc potential on their terminals. Shorting of terminals or the application of external voltages may result in board failure.
- Intermittent operation of electronic circuit boards is unlikely. Board failure will normally be permanent. If an intermittent condition is encountered, the cause will likely be a switch contact or a loose connection at a terminal or crimp.
- Solenoid removal requires interrupting the water supply to the valve. Damage may result if solenoids are energized for more than ten minutes without a supply of water.
- The use of two wrenches is recommended whenever plumbing fittings are tightened or loosened. This will help avoid twists and kinks in the tubing.
- Make certain that all plumbing connections are sealed and electrical connections tight and isolated.
- This brewer is heated at all times. Keep away from combustibles.

WARNING

- Exercise extreme caution when servicing electrical components. Disconnect the brewer from the power source before servicing.
- Follow recommended service procedures.
- Replace all protective shields or safety notices.

Problem	Probable Cause	Remedy
Equipment will not operate.	1. No power or incorrect voltage.	(A1) Check the terminal block for 120 volts across the red and white terminals and the black and white terminals on 120/208 or 120/240 volt brewers. (A2) Check the terminal block for 200 volts on "B Series" brewers or 240 volts on "A Series" brewers across the red and black terminals. (B) Check circuit breakers or fuses.
Brew cycle will not start.	1. No water 2. Water strainer/flow control (.750 GPM)	Check plumbing and shut-off valves (A) Direction of flow arrow must be pointing towards brewer. (B) Remove the strainer/flow control and check for obstructions. Clear or replace.

TROUBLESHOOTING (cont.)

Problem	Probable Cause	Remedy	
Brew cycle will not start (cont.)	3. ON/OFF switch	Refer to <i>Service</i> - ON/OFF switch for testing procedures. See page 24	
	4. Start switch	Refer to <i>Service</i> - Start switch for testing procedures. See page 32	
	5. Timer	Refer to <i>Service</i> - Timer for testing procedures. See page 34 or 36	
	6. Dispense valve	Refer to <i>Service</i> - Dispense valve for testing procedures. See page 20	
	7. Brew selector switch	Refer to <i>Service</i> - Brew selector switch for testing procedures. See page 16	
	Automatic refill will not operate	1. No water	Check plumbing and shut-off valves.
		2. Water strainer/flow control (.750 GPM)	(A) Direction of flow arrow must be pointing towards brewer.
(B) Remove the strainer/flow control and check for obstructions. Clear or replace.			
3. Solenoid valve		Refer to <i>Service</i> - Solenoid valve for testing procedures. See page 31	
4. Overflow protection switch		Refer to <i>Service</i> - Overflow protection switch for testing procedures. See page 25	
5. Level control board & level probe.		Refer to <i>Service</i> - Level control board for testing procedures. See page 22	
Beverage level will not adjust (Selector switch in any position)	1. Brew Selector switch	Refer to <i>Service</i> - Selector switch for testing procedures. See page 16	

TROUBLESHOOTING (cont.)

Problem	Probable Cause	Remedy
Water flows into tank continuously .	1. Solenoid valve	Refer to <i>Service</i> - Solenoid valve for testing procedures. See page 31
	2. Level control board and level probe	Refer to <i>Service</i> - Level control board for test procedures. See page 22
	3. Overflow protection switch	Refer to <i>Service</i> - Overflow protection switch for testing procedures. See page 25
Water flows into tank continuously (ON/OFF switch "ON").	1. Timer	Refer to <i>Service</i> - Timer for testing procedures. See page 34 or 36
Water from tank is not hot	1. Limit thermostat CAUTION - Do not eliminate or by-pass limit thermostat. Use only B.O.M. part #23717.0001	Refer to <i>Service</i> - Limit thermostat for testing procedures. See page 23
	2. Control Thermostat	Refer to <i>Service</i> - Control Thermostat for testing procedures. See page 19
	3. Contactor (Brewers with Recovery booster)	Refer to <i>Service</i> - Contactor for testing procedures. See page 18
	4. Tank heaters	Refer to <i>Service</i> - Tank heaters for testing procedures. See page 33
	5. Relay (Brewers with Recovery Booster)	Refer to <i>Service</i> - Relay for testing procedures. See page 27

TROUBLESHOOTING (cont.)

Problem

Probable Cause

Remedy

Spitting or unusual steaming from sprayhead or airvents.

1. Control thermostat
2. Lime build-up

CAUTION - Tank and tank components should be delimed regularly depending on local water conditions. Excessive mineral build-up on stainless steel surfaces can initiate corrosive reactions resulting in serious leaks.

Refer to *Service* - Control thermostat for testing procedures. See page 19

Inspect the tank assembly for excessive lime deposits. Delime as required.

Inconsistent beverage level in server.

1. Strainer/flow control (.750 GPM)

(A) Direction of flow arrow must be pointing towards the brewer.
(B) Remove the strainer/flow control and check for obstructions. Clear or replace.

2. Improper water pressure

Check the operating water pressure to the brewer. It must be between 20 and 90 psi.

3. Dispense valve

Refer to *Service* - Dispense valve for testing procedures. See page 20

4. Bypass valve

Refer to *Initial Set-Up* on page 4 step #7. For test procedure see page 15

Consistently high or low beverage level in server.

1. Timer adjustment

Adjust the timer as required to achieve the recommended volume for each brew cycle.

Dripping from sprayhead.

1. Dispense valve

Refer to *Service* - Dispense valve for testing procedures. See page 20

Water overflows server.

1. Bypass valve

Refer to *Initial Set-Up* on page 5 step #7. For test procedures see page 15

2. Needle valve

Refer to *Initial Set-Up* on Page 5 step #7.

TROUBLESHOOTING (cont.)

Problem	Probable Cause	Remedy
Water overflows filter (cont.)	3. Type of paper filters	BUNN paper filters should be used for proper extraction.
	4. No sprayhead	Check sprayhead
Beverage overflows server.	1. Beverage left in server	The brew cycle should be started only with an empty server under the funnel.
	2. Timer adjustment	Adjust the timer as required to achieve the recommended volume for each brew cycle. Refer to <i>Service</i> - Timer for testing procedures. See page 34 or 36
	3. Dispense valve	Refer to <i>Service</i> - Dispense valve for testing procedures. See page 20
Weak beverage	1. Type of paper filters	BUNN paper filters should be used for proper extraction.
	2. Coffee	A sufficient quantity of fresh drip or regular grind should be used for proper extraction.
	3. Sprayhead	B.O.M. Sprayhead #01082.0002 should be used to properly wet the bed of ground coffee in the funnel.
	4. Funnel loading	The BUNN paper filter should be centered in the funnel and the bed of ground coffee leveled by gentle shaking.
	5. Water temperature	Empty the server, remove its cover. Place empty funnel over the server entrance, with ON/OFF switch in the "ON" position press the start switch and release it. Check the water temperature immediately below the sprayhead with a thermometer. The reading should not be less than 195° F.

TROUBLESHOOTING (cont.)

Problem	Probable Cause	Remedy
Brewer is making unusual noises.	1. Solenoid valve	The nut on back of the solenoid must be tight or it will vibrate during operation
	2. Plumbing lines	Plumbing lines should not be resting on the counter top.
	3. Water supply	(A) The brewer must be connected to a cold water line.
		(B) Water pressure to the brewer must not be higher than 90 psi. Install a regulator if necessary to lower the working pressure to approximately 50 psi.
	4. Tank heaters	Remove and clean lime off tank heaters.
5. Contactor	Check for low voltage	
Server will not heat	1. Circuit breaker	A) Check and reset if necessary B) Refer to <i>Service</i> - Circuit breaker for test procedures. See page 17
	2. Receptacle Contacts	Clean or replace. See page 26
	3. Relay (Server Power) (Prior to S.N. DUAL026000)	Refer to <i>Service</i> - Relay (Soft Heat) for test procedures. See page 29
	4. Transformer	Refer to <i>Service</i> - Transformer for test procedures. See page 38
	5. Rectifier	Refer to <i>Service</i> - Rectifier for test procedures. See page 26

SERVICE

This section provides procedures for testing and replacing various major components used in this brewer should service become necessary. Refer to *Troubleshooting* for assistance in determining the cause of any problem.

WARNING - Inspection, testing, and repair of electrical equipment should be performed only by qualified service personnel. The brewer should be unplugged when servicing, except when electrical tests are required and the test procedure specifically states to plug in the brewer.

COMPONENT ACCESS

WARNING - Unplug the brewer before the removal of any panel or the replacement of any component.

All components are accessible by the removal of the top cover, front inspection panel and server platform.

The top cover is attached with four #4-40 slotted head screws.

The front inspection panel is attached with eleven #6-32 slotted head screws.

The server platform is attached with four #6-32 slotted head screws.

Contents

Brew Selector Switches	16
Bypass Valves	15
Circuit Breakers.....	17
Contactor Assembly.....	18
Control Thermostat.....	19
Dispense Valves.....	20
Grinder Selector Switch	21
Level Control Board and Level Probe	22
Limit Thermostat.....	23
Main ON/OFF Switch	40
ON/OFF Switches (Enable Brew)	24
Overflow Protection Switch.....	25
Receptacles (Spring Contacts).....	26
Rectifiers.....	26
Relays (Recovery Boost).....	27
Relays (Server Power)	29
Solenoid.....	31
Start Switches	32
Tank Heaters	33
Timers.....	34,36
Transformer	38
Wiring Diagrams.....	41-44

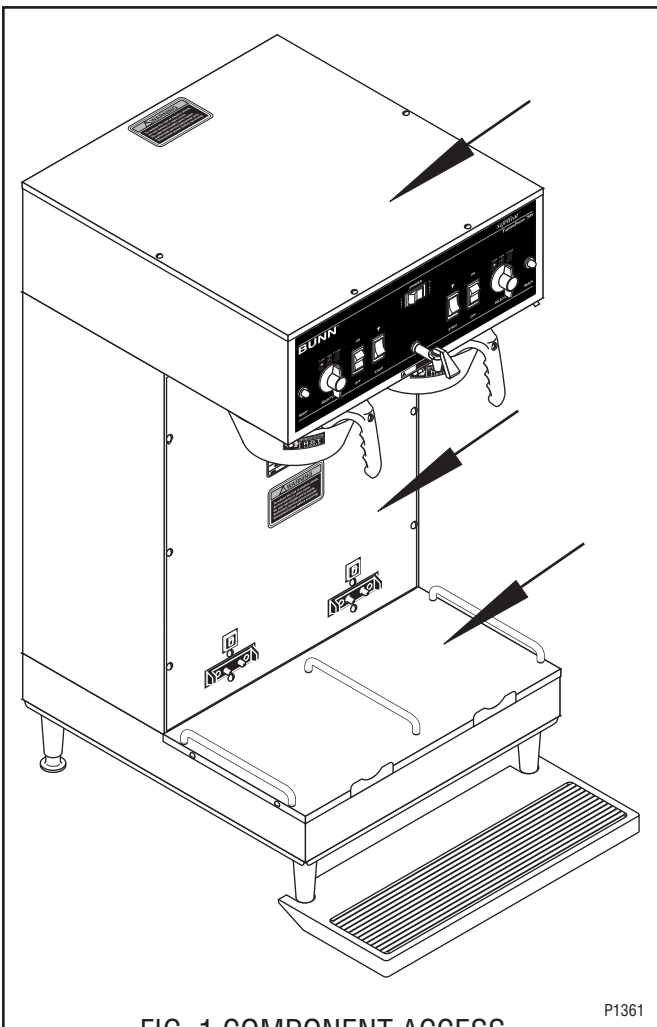
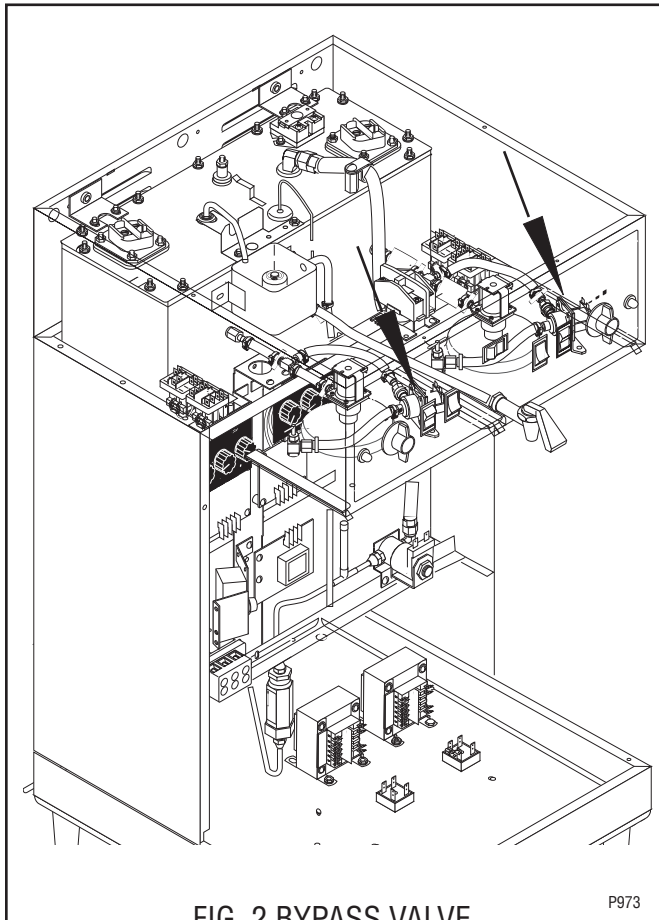

FIG. 1 COMPONENT ACCESS

P1361

SERVICE (cont.)

BYPASS VALVE



Location:

The bypass valves are located inside the right front and the center front of the hood.

Test Procedures:

1. Disconnect the brewer from the power source and place 1.5 or 1.75 gallon server under the funnel.
2. Disconnect the white/green wire and the white/violet wire on the bypass valve.
3. Check the voltage across the white/green and the white/violet wires with a voltmeter. Connect the brewer to the power source. With the "ON/OFF" switch in the "ON" position, the selector switch in the 1.5 or 1.75 gallon position press the start switch. The indication must be:
 - a.) 120 volts ac for three wire 120/208 volt models and three wire 120/240 volt models.
 - b.) 200 to 240 volts ac for two wire 200, 230 or 240 volt models.
4. Disconnect the brewer from the power source.

If voltage is present as described, proceed to #5.

If voltage is not present as described refer to the wiring diagrams and check the brewer wiring harness.

5. Check for continuity across the bypass valve coil terminals.

If continuity is present as described, reconnect the white/green and white/violet wires to the bypass valve and proceed to #6.

If continuity is not present as described, replace the bypass valve.

6. Check the bypass valve for coil action. Connect brewer to the power source. With the "ON/OFF" switch in the "ON" position press the start switch. Listen carefully in the vicinity of the by-pass valve for a "clicking" sound as the coil attracts and repels the plunger.

If the sound is heard as described, there may be a blockage in the water line before the bypass valve or the bypass valve may require inspection for wear and removal of waterborne particles.

If the sound is not heard as described, replace the bypass valve.

Removal and Replacement:

1. Remove the wires from the bypass valve.
2. Drain enough water from the tank so bypass valve is above the water level
3. Remove water lines from bypass valve.
4. Remove the two nuts retaining the bypass valve inside the hood and remove bypass valve.
5. Remove hose barb fitting and attach to new bypass valve.
6. Install new bypass valve with hose barb fitting.
7. Reconnect the water tubes and the wires to the bypass valve.
8. Refer to Fig. 3 when reconnecting the wires.

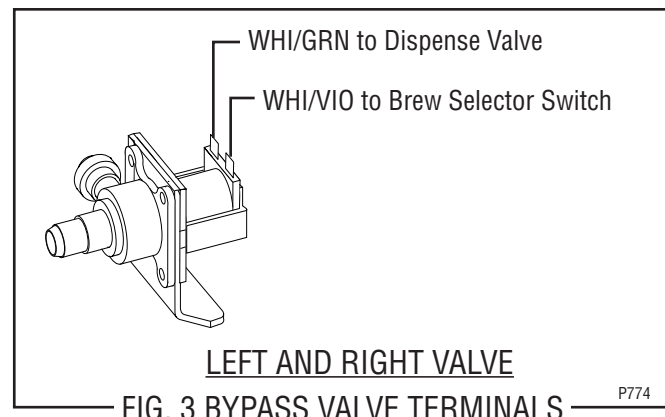

SERVICE (cont.)

BREW SELECTOR SWITCH

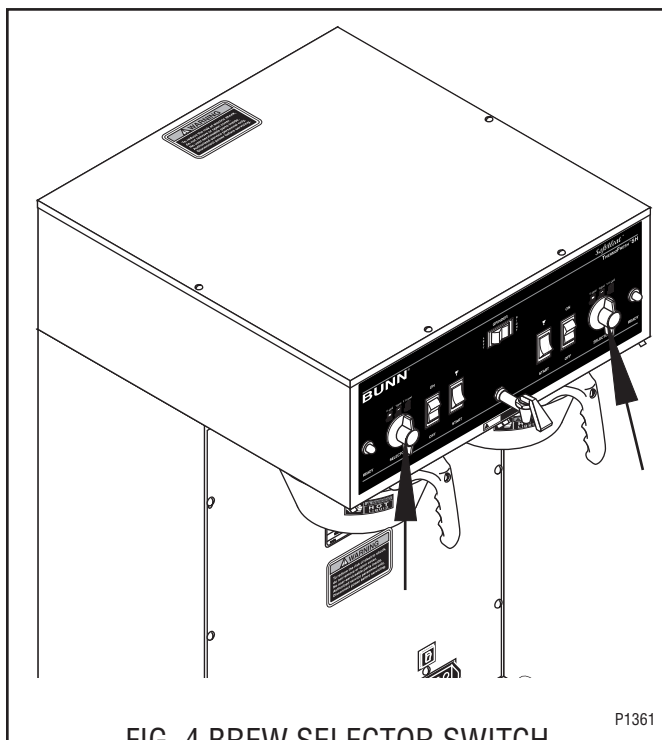

FIG. 4 BREW SELECTOR SWITCH

Location:

The brew selector switches are located in the front left and right side of the hood.

Test Procedure:

Timer: Left or Right

1. Disconnect the brewer from the power supply.
2. Separate the connector on the selector switch harness from the brew timer circuit board.
3. Carefully slide the plastic cover off of the connector from the switch harness.
4. Check for continuity across the pink and tan wires on the connector when the switch is in the 1/2 gallon position. Continuity must not be present in any other switch position.
5. Check for continuity across the pink wire and gray wire when the switch is in the 1 gallon position. Continuity must not be present in any other position.
6. Reattach the connector to the brew timer circuit board.

Grinder Interface: Left or Right:

7. Disconnect the gray and tan wires on the selector switch from the gray and tan wires on the interface socket.

8. Disconnect the pink wire on the selector switch from the grinder switch.
9. Check for continuity across the pink wire and tan wire on the selector switch when the switch is in the 1/2 gallon position. Continuity must not be present in any other position.
10. Check for continuity across the pink wire and gray wire on the selector switch when the switch is in the 1 gallon position. Continuity must not be present in any other position.
11. Reconnect the gray and tan wire on the selector switch to the gray and tan wires on the interface socket.
12. Reconnect the pink wire on the selector switch to the grinder switch.

Bypass Valve: Left or Right

13. Disconnect the white/violet on the selector switch from the bypass valve coil and disconnect the white/red from the dispense valve coil.
14. Check for continuity across the white/violet and the white/red wires when the selector is in the 1 gallon, 1-1/2 gallon or 1-3/4 gallon position. Continuity must not be present in any other position.
15. Reconnect the white/violet to the bypass valve coil and white/red to the dispense valve coil.

Removal and Replacement:

1. Disconnect the connector on the selector switch harness from the brewer timer circuit board.
2. Disconnect wires from the selector switch, interface socket, dispense valve and bypass valve.
3. Loosen the set screw on the switch knob.
4. Remove the 9/16" nut and washer holding the switch to the hood.
5. Remove the switch.
6. Install the new switch. The positioning tab must be in the hole in the hood for proper switch and knob alignment.
7. Install the knob so that the arrow points to the 1-1/2 or 1-3/4 gallon position when the switch is turned to the full right position.
8. Reattach the connector to the brew timer circuit board.
9. Refer to Fig. 5 when reconnecting the wires.

SERVICE (cont.)

BREW SELECTOR SWITCH (cont.)

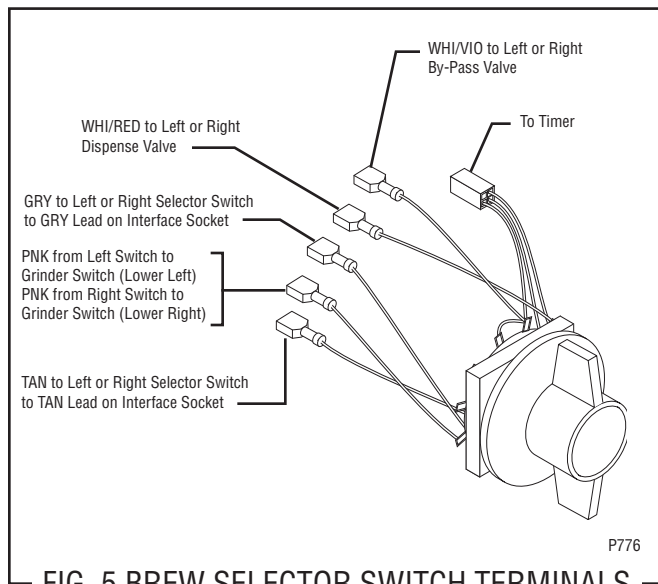

FIG. 5 BREW SELECTOR SWITCH TERMINALS

CIRCUIT BREAKERS

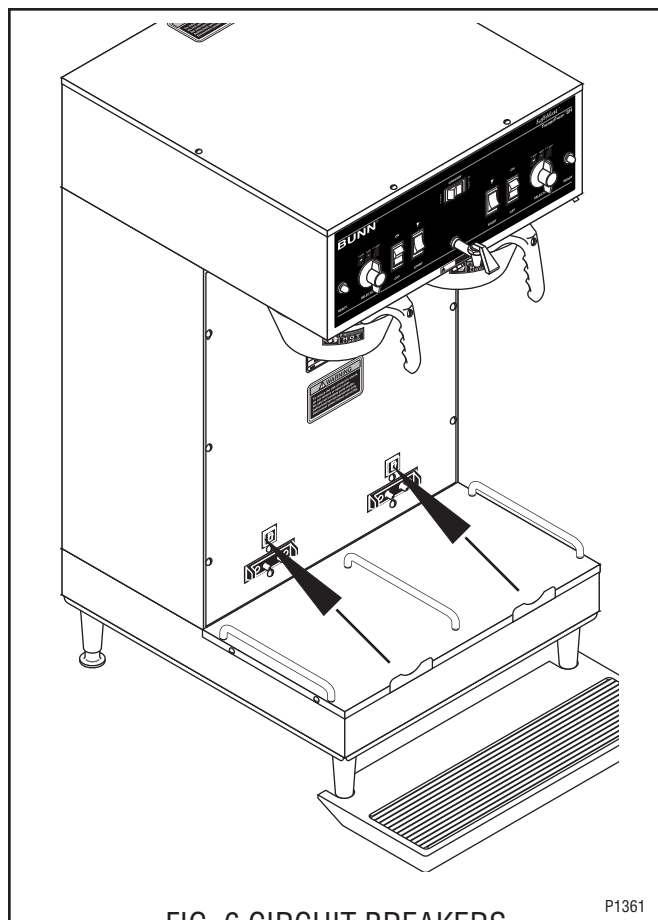

FIG. 6 CIRCUIT BREAKERS

Location

The circuit breakers are located on the lower front of the brewer, mounted on the server platform just above the spring contact receptacle assembly.

Test Procedures:

1. Disconnect the dispenser from the power source.
2. Remove the wires from the circuit breaker.
3. Check for continuity between the terminals. Continuity must be present between the terminals.

If continuity is present as described the circuit breaker is functioning properly.

If continuity is not present as described, press reset button and repeat step #3, if continuity is not present as described, replace the circuit breaker.

Removal and Replacement:

1. Remove the wires from the circuit breaker.
2. Compress the clips on the back side of the server platform and gently push the circuit breaker through the opening in the server platform.
3. Push the new circuit breaker into the opening in the server platform until the clips snap into position.
4. Reconnect the wires to the circuit breaker.
5. Refer to Fig. 7 when reconnecting the wires.

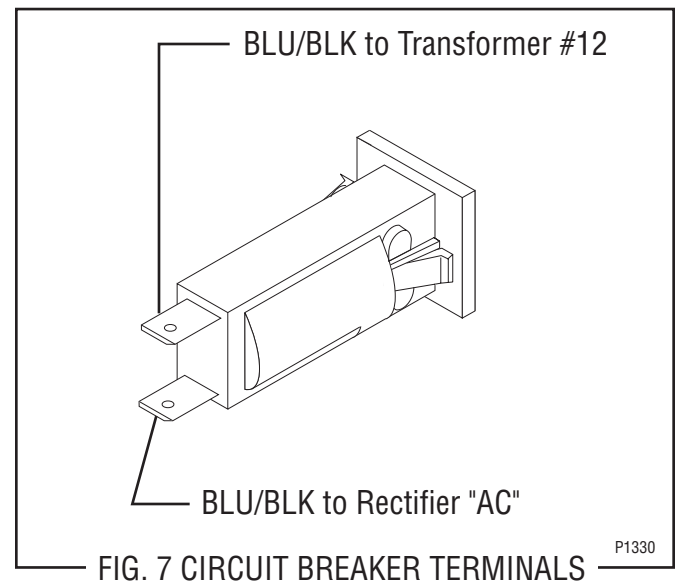

FIG. 7 CIRCUIT BREAKER TERMINALS

SERVICE (cont.)

CONTACTOR ASSEMBLY

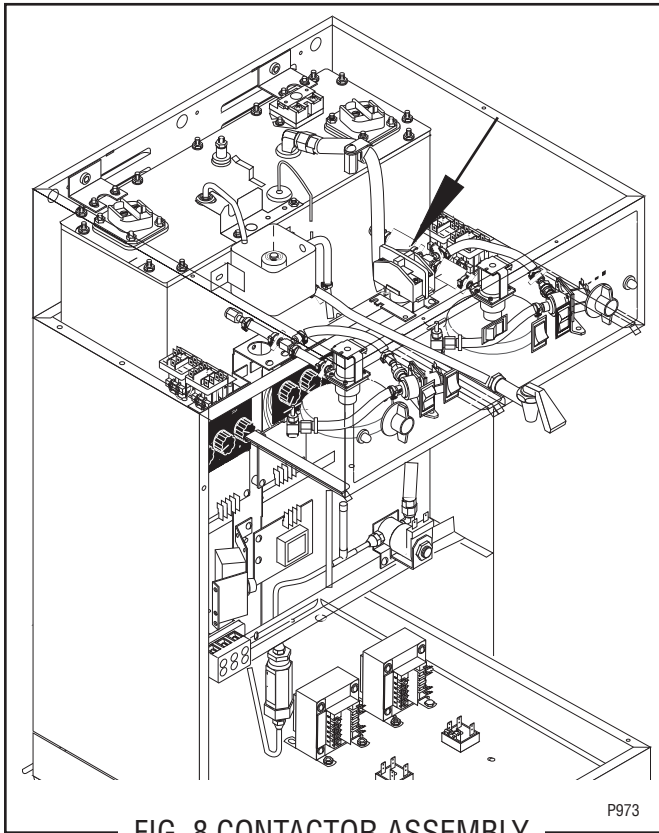

FIG. 8 CONTACTOR ASSEMBLY

Location:

The contactor assembly is located inside the hood just to the rear of the right dispense valve.

Test Procedures:

Mechanical Thermostat (Brewers with or without Recovery Booster)

1. Disconnect the brewer from the power source.
2. Disconnect the red wire of the two pole 200V or 240V terminal block or the white wire of the three pole 120/208V or 120/240V terminal block from the black wire of the contactor coil and disconnect the black wire of the control thermostat from the remaining black wire of the contactor coil.
3. Gently remove the capillary bulb and grommet from the tank.
4. Adjust the thermostat clockwise to the "FULL ON" position, and with a voltmeter check the voltage across the white wire from the terminal block on 120/208, 120/240 volt units or the red wire from 200, 230 or 240 volt units and the black wire from the control thermostat. Connect the brewer to the

power source. The indication must be:

- a.) 120 volts ac for three wire 120/208 volt models and three wire 120/240 volt models.
 - b.) 200 to 240 volts ac for two wire 200,230 or 240 volt models.
5. Disconnect the brewer from the power source.

If voltage is present as described, proceed to #6. If voltage is not present as described, refer to the wiring diagrams and check the brewer wiring harness.

6. Check for continuity between the two black wires of the contactor coil.

If continuity is present as described, reconnect one black wire to red or white wire from the terminal block and the other black wire to the black wire from the control thermostat. Reinstall capillary tube into the tank to a line 7" above the bulb and proceed to #7. If continuity is not present as described, replace the contactor.

7. Locate the red wire on the L1 terminal and black wire on the L2 terminal on the contactor.
8. Carefully check the voltage across the red and black with a voltmeter. The indication must be:
 - a.) 208 volts ac for three wire 120/208 volt models and 240 volts ac for three wire 120/240 volt models.
 - b.) 200 to 240 volts ac for two wire 200, 230 or 240 volt models.
9. Disconnect the brewer from the power source.

If voltage is present as described, proceed to #10. If voltage is not present as described, refer to the wiring diagrams and check the brewer wiring harness.

10. Check for continuity across the terminals on the left side of the contactor by manually closing the contacts. Continuity must not be present when the contact is released.
11. Check for continuity across the terminals on the right side of the contactor by manually closing the contacts. Continuity must not be present when the contact is released.

If continuity is present as described, the contactor is operating properly.

If continuity is not present as described, replace the contactor.

SERVICE (cont.)

CONTACTOR ASSEMBLY (cont.)

Removal and Replacement:

1. Remove all wires from the contactor.
2. Remove the two #10-32 slotted head screw securing contactor to the inside of the hood.
3. Securely install the new contactor inside the hood.
4. Refer to Fig. 9 when reconnecting the wires.

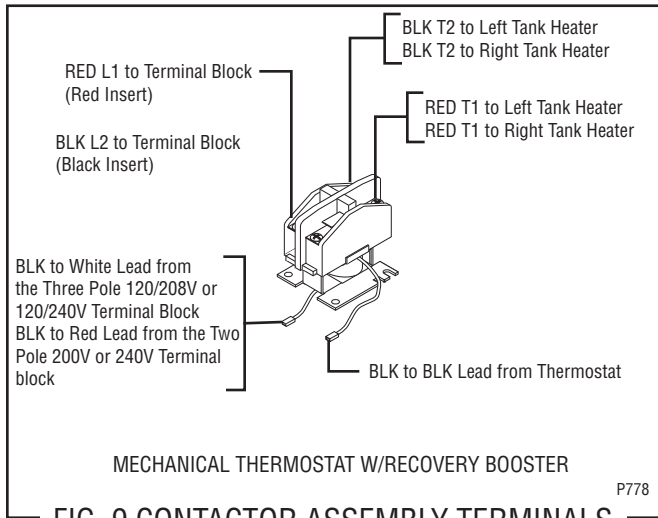

FIG. 9 CONTACTOR ASSEMBLY TERMINALS

CONTROL THERMOSTAT

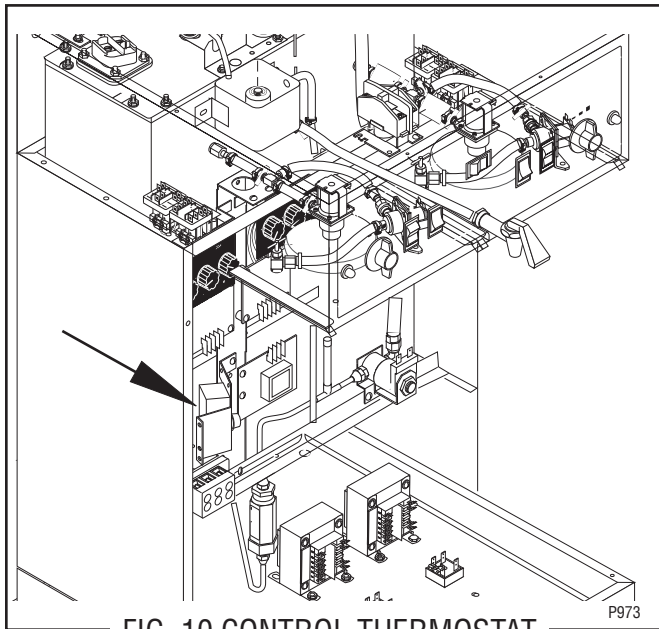

FIG. 10 CONTROL THERMOSTAT

Location:

The control thermostat is located inside the lower left front of the brewer on the component bracket.

Test Procedures

1. Disconnect the brewer from the power source.
2. Locate the blue wire on the control thermostat.
3. With a voltmeter check the voltage across the blue wire on the control thermostat and the white insert on three pole 120/208V, 120/240V terminal block or the red insert on two pole 200V, 240V terminal block. Connect the brewer to the power source. The indication must be:
 - a.) 120 volts ac for three wire 120/208 volt models and three wire 120/240 volt models.
 - b.) 200 to 240 volts ac for two wire 200, 230 or 240 volt models.
4. Disconnect the brewer from the power source.

If voltage is present as described, proceed to #5. If voltage is not present as described, refer to the wiring diagrams and check the brewer wiring harness.

5. Locate the black wires from the control thermostat.
6. Gently remove the capillary bulb and grommet from the tank.
7. Check the voltage across the black wires of the control thermostat and the white insert on the three pole 120/208V, 120/240V terminal blocks or the red insert on two pole 200V, 240V terminal blocks with a voltmeter when the control thermostat is turned "ON" (fully clockwise). Connect the brewer to the power source. The indication must be:
 - a.) 120 volts ac for three wire 120/208 volt models and three wire 120/240 volt models.
 - b.) 200 to 240 volts ac for two wire 200, 230 or 240 volt models.Voltage must not be indicated across these terminals when the thermostat is turned "OFF" (fully counterclockwise).
8. Disconnect the brewer from the power source.

If voltage is present as described, reinstall the capillary tube into the tank to the line 7" above the bulb, the control thermostat is operating properly.

If voltage is not present as described, replace the thermostat.

Removal and Replacement:

1. Remove wires from the control thermostat.
2. Remove the thermostat capillary bulb by firmly

SERVICE (cont.)

CONTROL THERMOSTAT (cont.)

pulling up on the capillary tube at the tank lid. This will disengage the grommet from the tank lid.

3. Remove the #8-32 slotted head screw holding the control thermostat to the component bracket.
4. Slide the grommet to the line 7" above the bulb on the new capillary tube.
5. Insert the capillary bulb through the hole in the tank lid and press the grommet firmly and evenly so that the groove in the grommet fits into the tank lid.
6. Carefully bend the capillary tube so that the tube and bulb inside the tank are in the vertical position.

NOTE - The capillary tube must be clear of any electrical termination and not kinked.

7. Using a #8-32 slotted head screw fasten the control thermostat to the component bracket.
8. Refer to Fig. 11 when reconnecting the wires.
9. Adjust the control thermostat as required.

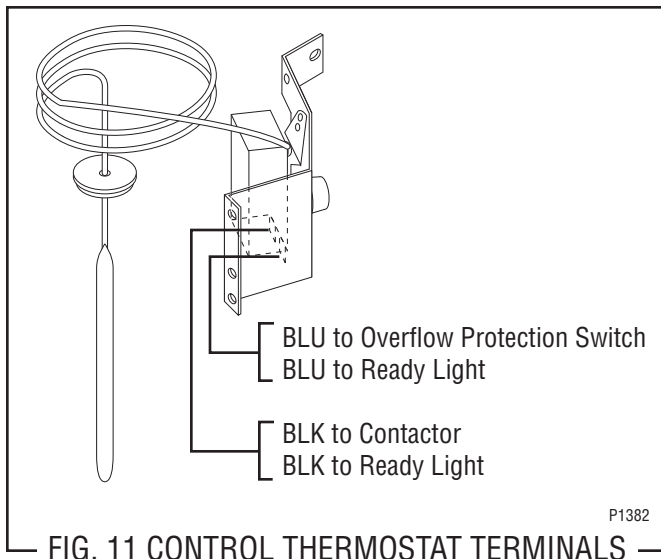

FIG. 11 CONTROL THERMOSTAT TERMINALS

DISPENSE VALVE

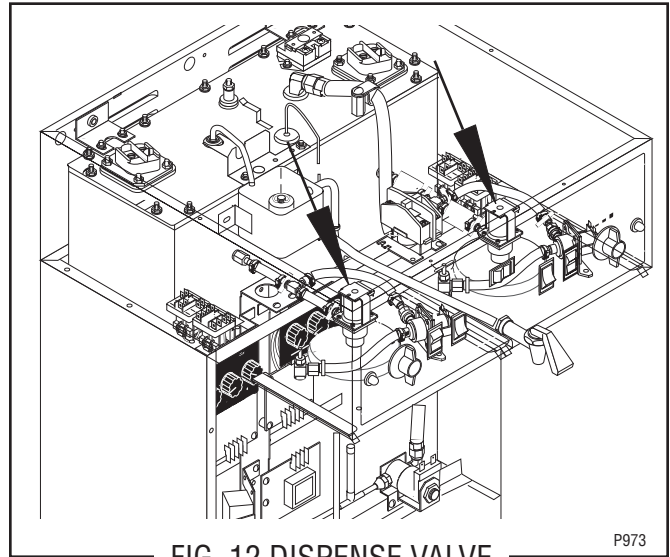

FIG. 12 DISPENSE VALVE

Location:

Dispense valves are located inside the hood in the center of each sprayhead panel.

Test Procedures:

1. Disconnect the brewer from the power source.
2. Disconnect the wires from the right dispense valve and check the voltage across the white/violet wire and white/green wire. Connect brewer to the power source. Place the "ON/OFF" switch in the "ON" position, press and release the start switch. The indication must be:
 - a.) 120 volts ac for three wire 120/208 volt models and three wire 120/240 volt models.
 - b.) 200 to 240 volts ac for two wire 200, 230 or 240 volt models.
3. Disconnect brewer from the power source.
4. Disconnect the wires from the left dispense valve and check voltage across the white/red wire and the white/brown wire. Connect the brewer to the power source. Place the "ON/OFF" switch in the "ON" position, press and release the start switch. The indication must be:
 - a.) 120 volts ac for three wire 120/208 volt models and three wire 120/240 volt models.
 - b.) 200 to 240 volts ac for two wire 200, 230 or 240 volt models.
5. Disconnect brewer from power source.

If voltage is present as described in steps 2 & 4 proceed to #6.

If voltage is not present as described, refer to the wiring diagrams and check the brewer wiring harness.

SERVICE (cont.)
DISPENSE VALVE (cont.)

6. Check for continuity across the dispense valve coil terminals.

If continuity is present as described, reconnect the wires to the dispense valve(s) and proceed to #7
 If continuity is not present as described, replace the dispense valve.

7. Check the dispense valve for coil action. Connect the brewer to power source. Place the ON/OFF switch in the "ON" position, press and release the start switch. Listen carefully in the vicinity of the dispense valve for a "clicking" sound as the coil magnet attracts and repels the plunger.
8. Disconnect the brewer from the power source.

If the sound is heard as described, there may be a blockage in the dispense valve or the water line to the dispense valve. Remove the dispense valve and inspect for wear, and remove waterborne particles.
 If the sound is not heard as described, replace the dispense valve.

Removal and Replacement:

1. Drain enough water from the tank so the dispense valves are above the water level.
2. Disconnect wires and water tubes from dispense valve.
3. Remove dispense valve from the sprayhead panel.
4. Install new dispense valve.
5. Reconnect the water lines and the wires to the dispense valve.
6. Refer to Fig. 13 when reconnecting wires.

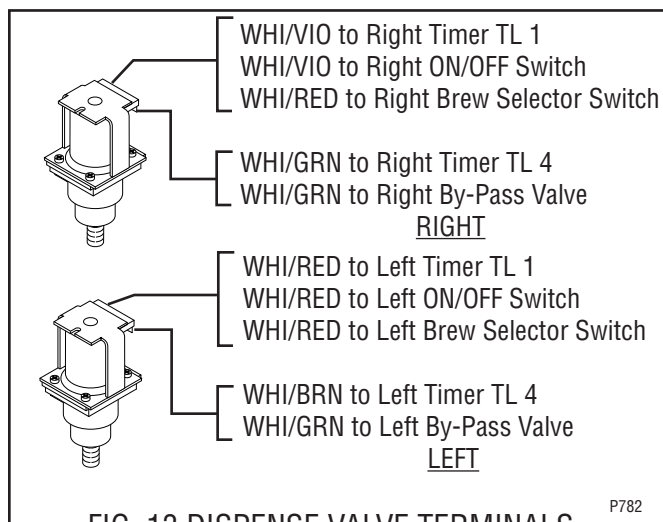

FIG. 13 DISPENSE VALVE TERMINALS

GRINDER SELECTOR SWITCH

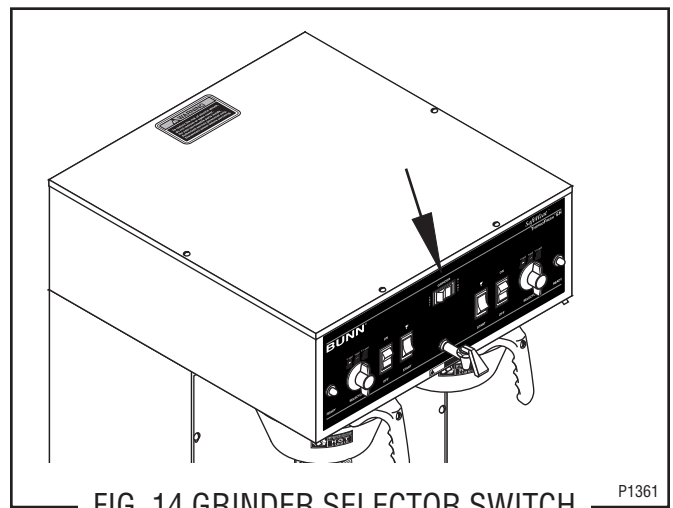

FIG. 14 GRINDER SELECTOR SWITCH

Location:

The grinder selector switch is located in the upper center on the front of the hood.

Test Procedure:

1. Disconnect the brewer from the power source.
2. Remove all wires from the switch terminals.
3. Place the selector switch in the left position.
4. Check for continuity across the center and right terminals on the rear of the switch.
5. Continuity must not be present across the center and left terminals on the rear of the switch.
6. Check the bottom row, then the top row of terminals.

If continuity is present as described proceed to #7.
 If Continuity is not present as described replace the switch.

7. Place the selector switch in the right position.
8. Check for continuity across the center and left terminals on the rear of the switch.
9. Continuity must not be present across the center and right terminals on the rear of the switch.
10. Check the bottom row, then the top row.

If continuity is present as described, reconnect the wires, the switch is operating properly.
 If continuity is not present as described, replace the switch.

11. Refer to Fig. 15 when reconnecting the wires.

SERVICE (cont.)

GRINDER SELECTOR SWITCH (cont.)

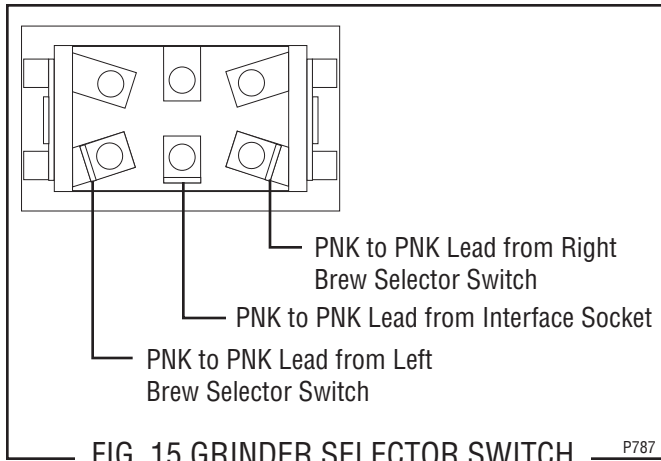

FIG. 15 GRINDER SELECTOR SWITCH TERMINALS P787

LEVEL CONTROL BOARD AND LEVEL PROBE

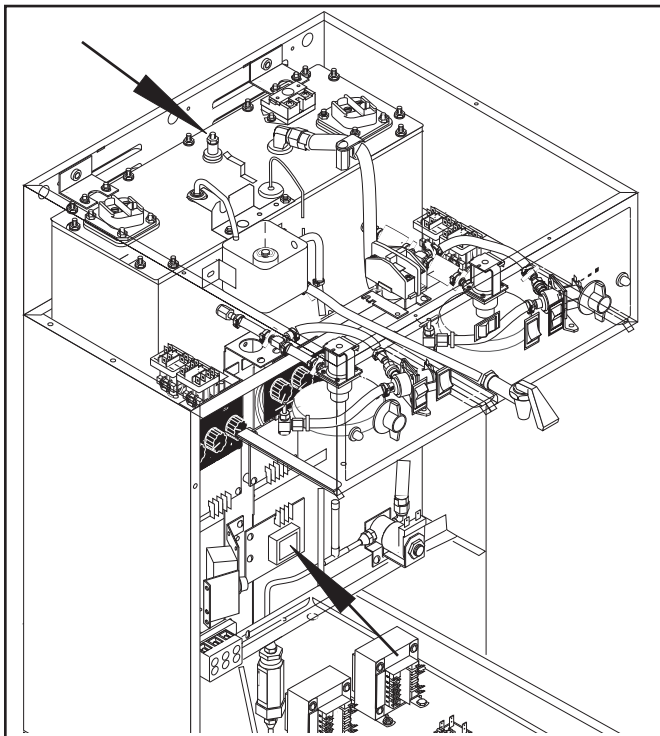

FIG. 16 LEVEL CONTROL BOARD AND LEVEL PROBE P973

Location:

The level control board is located inside the front of the brewer just left of center on the component bracket

Test Procedure:

1. Disconnect the brewer from the power source.
2. Remove the violet wire from terminal 1 & the pink wire from terminal 4 of the circuit board.

3. With a voltmeter check the voltage across terminals 2 & 3. Connect the brewer to the power source. The indication must be:
 - a.) 120 volts ac for three wire 120/208 volt models and three wire 120/240 volt models.
 - b.) 200 to 240 volts ac for two wire 200, 230 or 240 volt models.
4. Disconnect the brewer from the power source.

If voltage is present as described, proceed to #5. If voltage is not present as described, refer to the wiring diagrams and check the brewer wiring harness.

5. Reconnect the violet wire to terminal 1.
6. Carefully connect a piece of insulated jumper wire to terminal 4. Keep the other end of this wire away from any metal surface of the brewer.
7. With a voltmeter check the voltage across terminals 1 & 3. Connect the brewer to the power source. The indication must be:
 - a.) 120 volts ac for three wire 120/208 volt models and three wire 120/240 volt models after a delay of approximately 1 second.
 - b.) 200 to 240 volts ac for two wire 200, 230 or 240 volt models after a delay of approximately 1 second.
8. Touch the free end of jumper wire to the brewer housing. The indication must be 0.
9. Move the jumper wire away from the brewer housing. The indication must again be:
 - a.) 120 volts ac for three wire 120/208 volt models and three wire 120/240 volt models after a delay of approximately 1 second.
 - b.) 200 to 240 volts ac for two wire 200, 230 or 240 volt models after a delay of approximately 1 second.
10. Disconnect the brewer from the power source and remove the jumper wire from terminal 4.

If voltage is present as described, the level control board is operating properly, proceed to #11.

If voltage is not present as described, replace the level control board.

11. Reconnect the pink wire to terminal 4.
12. Gently pull the probe out of the tank lid and inspect for corrosion. Replace it if necessary.
13. Place the probe so that neither end is in contact with any metal surface of the brewer.
14. With a voltmeter check the voltage across terminals 1 & 3. Connect the brewer to the power source.

SERVICE (cont.)

LEVEL CONTROL BOARD AND LEVEL PROBE (cont.)

The indication must be:

- a.) 120 volts ac for three wire 120/208 volt models and three wire 120/240 volt models after a delay of approximately 1 second.
 - b.) 200 to 240 volts ac for two wire 200, 230 or 240 volt models after a delay of approximately 1 second.
15. Move the probe's flat end to the brewer housing. The indication must be 0.
16. Move the probe's flat end away from the brewer housing. The indication should again be
- a.) 120 volts ac for three wire 120/208 volt models and three wire 120/240 volt models after a delay of approximately 1 second.
 - b.) 200 to 240 volts ac for two wire 200, 230 or 240 volt models after a delay of approximately 1 second.
17. Disconnect the brewer from the power source.

If voltage is present as described, reinstall the probe, the level control board and level probe are operating properly.

If voltage is not present as described, check the pink probe wire for continuity.

Removal and Replacement:

1. Remove all wires from the level control board.
2. Remove two #8-32 slotted head screws holding level control board to component bracket.
3. Install the new level control board to the component bracket. Make certain that the lockwashers are between the level control board and the component bracket.
4. Refer to Fig. 17 when reconnecting the wires.

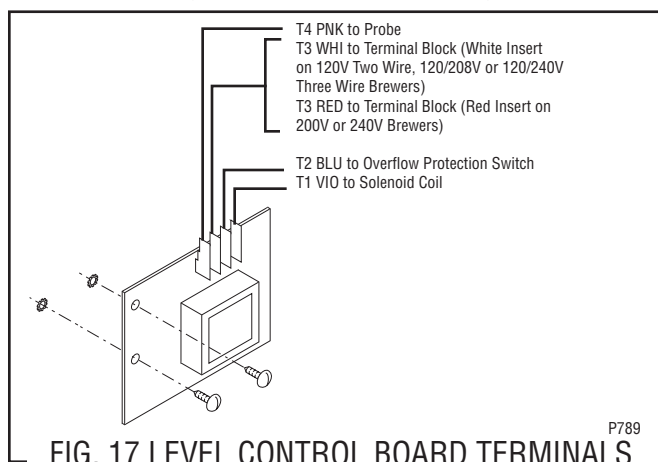

LIMIT THERMOSTAT

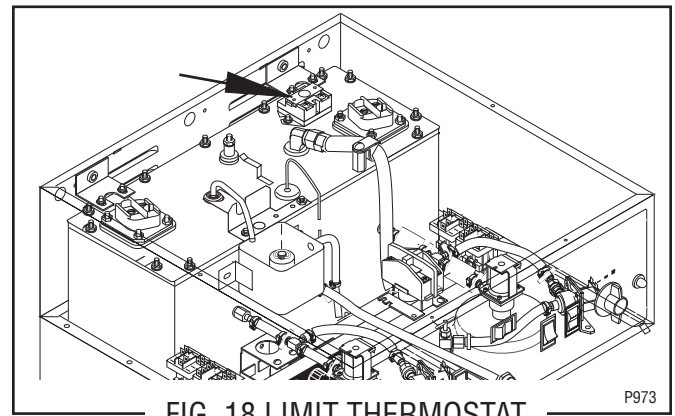

Location:

The limit thermostat is located inside the hood on the tank lid just to the left of the right tank heater.

Test Procedure:

1. Disconnect the brewer from the power supply.
2. Disconnect the black wires from the limit thermostat.
3. Check continuity across the limit thermostat terminals with an ohm meter

If continuity is present as described, reconnect the black wires to the limit thermostat, the limit thermostat is operating properly.

If continuity is not present as described, press the reset button on the limit thermostat and repeat step #3. After repeating step #3 no continuity is shown, replace the limit thermostat.

Removal and Replacement:

1. Remove all wires from the limit thermostat terminals.
2. Carefully remove the two #8-32 nuts securing the limit thermostat to tank lid and remove limit thermostat.
3. Carefully secure new limit thermostat to tank lid.
4. Refer to Fig. 19 when reconnecting the wires.

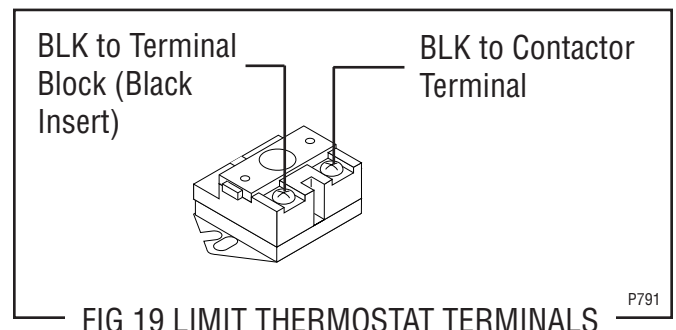

SERVICE (cont.)

ON/OFF SWITCH

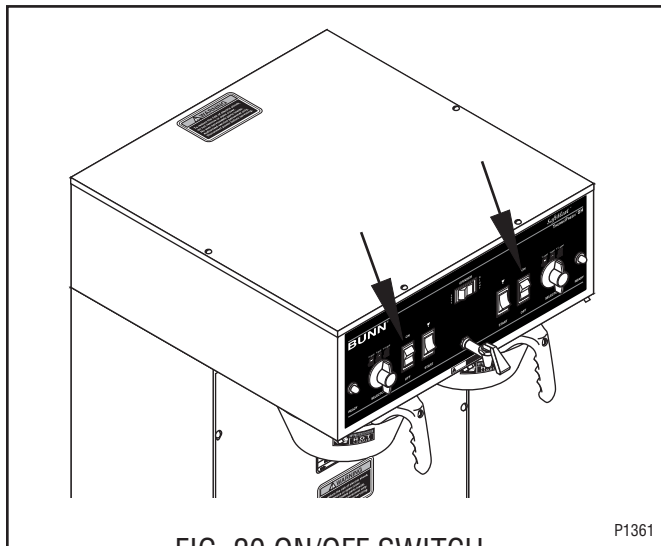

FIG. 20 ON/OFF SWITCH

Location:

The ON/OFF switches are located on the front of the hood just to the left and right of the start switches.

Test Procedure:

1. Disconnect the brewer from the power source.
2. Viewing the switch from the back remove the white or red wire from the upper right terminal and the black wire from the center terminal.
3. With a voltmeter check the voltage across the white wire and the black wire or red and black wire. Connect the brewer to the power source. The indication must be:
 - a.) 120 volts ac for three wire 120/208 volt models and three wire 120/240 volt models.
 - b.) 200 to 240 volts ac for two wire 200, 230 or 240 volt models.
4. Disconnect the brewer from the power source.

If voltage is present as described, reconnect the white or the red wire, and proceed to #5.

If voltage is not present as described, refer to the *Wiring Diagrams* and check the brewer wiring harness.

5. With the black wire removed, remove the white/red wire on the left switch or the white/violet wire on the right switch from the lower left terminal.
6. Check for continuity across the center and lower left terminal with switch in the "ON" position. Continuity must not be present when switch is in the "OFF" position.

If continuity is present as described, reconnect the black wire to the center terminal and the white/red wire on the left switch or the white/violet on the right switch to the lower left terminal.

If continuity is not present as described, replace the switch.

Removal and Installation:

1. Remove the wires from the switch terminals.
2. Compress the clips inside the hood and gently push the switch through the opening.
3. Push the new switch into the opening and spread the clips to hold switch in the hood.
4. Refer to Fig. 21 when reconnecting the wires.

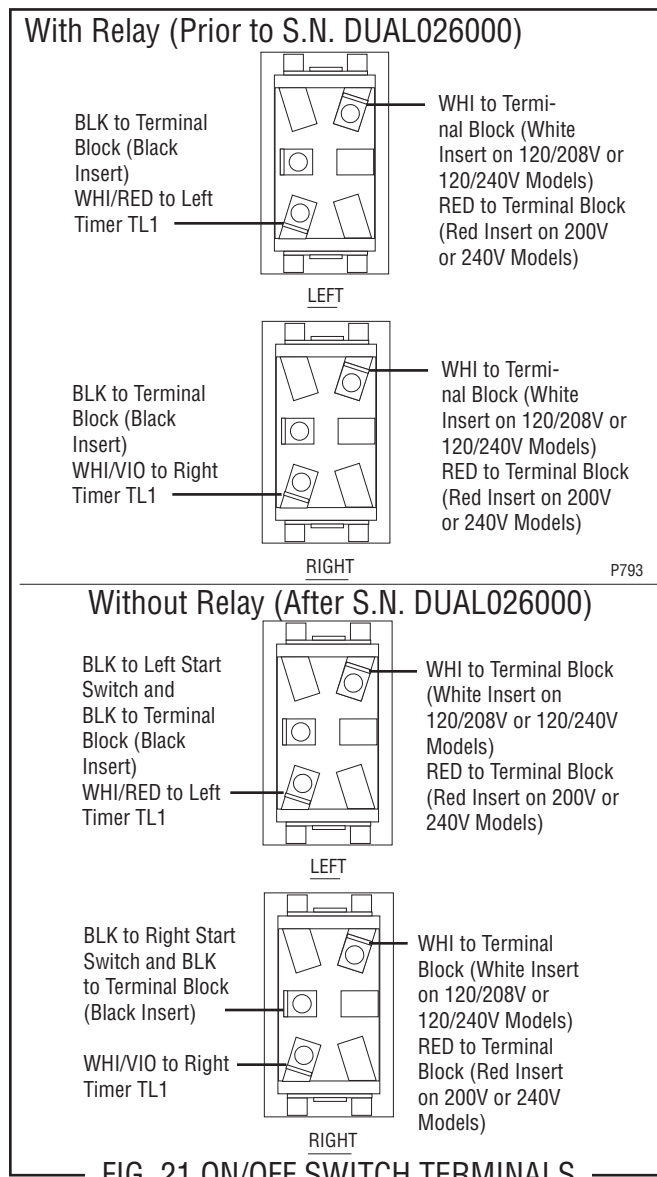

FIG. 21 ON/OFF SWITCH TERMINALS

SERVICE (cont.)

OVERFLOW PROTECTION SWITCH

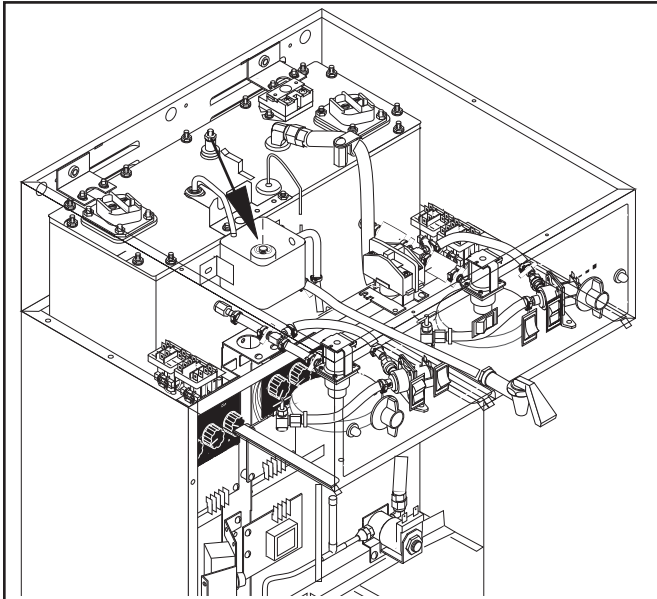

FIG. 22 OVERFLOW PROTECTION SWITCH

Location:

The overflow protection switch is located inside the hood on the left side of the tank inside the copper overflow cup.

To test the overflow protection switch, access will also be needed to the level control board and terminal block.

Test Procedure:

1. Disconnect the brewer from the power source.
2. Remove the wire nuts connecting the red wires from the overflow protection switch to the black wire from the terminal block and blue wire from the thermostat.
3. Check for continuity across the overflow protection switch red wires only until the plastic float is raised and check that continuity returns when the plastic float is again lowered.

If continuity is present as described, reconnect the red wires to the blue wire from the thermostat and the black wire from terminal block.

If continuity is not present as described, replace the overflow protection switch.

Removal and Replacement:

1. Disconnect the red leads from the overflow protection switch from the blue wire from the thermostat and the black wire from the terminal block.
2. Remove the nut beneath the copper overflow cup.
3. Remove the entire switch assembly from the cup.
4. Place the new switch assembly into the cup, wires first. Make sure that the gasket is in place around the threaded switch stem.

NOTE - The magnets must be at the top of float and there must be NO adjusting washers installed for the overflow protection switch to operate properly.

5. Install the nut beneath the copper overflow cup. Be sure not to overtighten.
6. Refer to Fig. 23 when reconnecting wires.

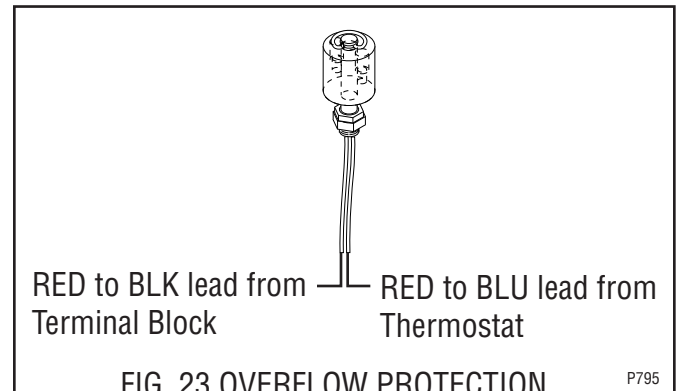

FIG. 23 OVERFLOW PROTECTION SWITCH LEADS

SERVICE (cont.)
RECEPTACLE ASSEMBLIES

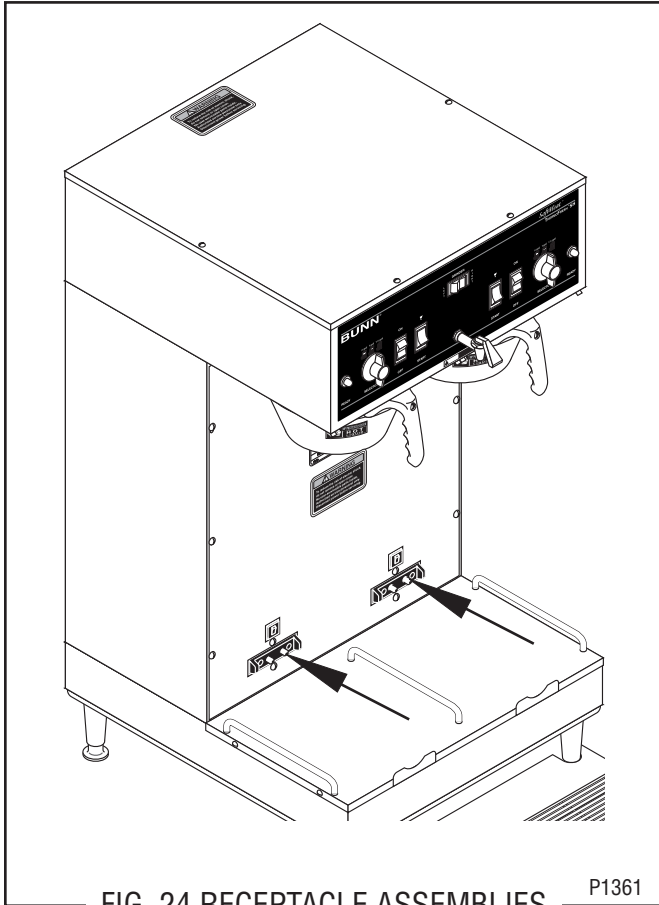

FIG. 24 RECEPTACLE ASSEMBLIES P1361

Location:

The receptacle assemblies are located on the lower left and right front of the brewer mounted on the server platform.

Test Procedures:

1. Clean or replace spring contacts.

Removal and Replacement:

1. Disconnect the brewer from the power source.
2. Disconnect the wires from the receptacle assembly.
3. Remove the two #6-32 flat head screws securing the receptacle to the server platform.
4. Remove and discard receptacle.
5. Install new receptacle in the server platform and secure two #6-32 flat head screws..
6. Refer to Fig. 25 and reconnect the wires.

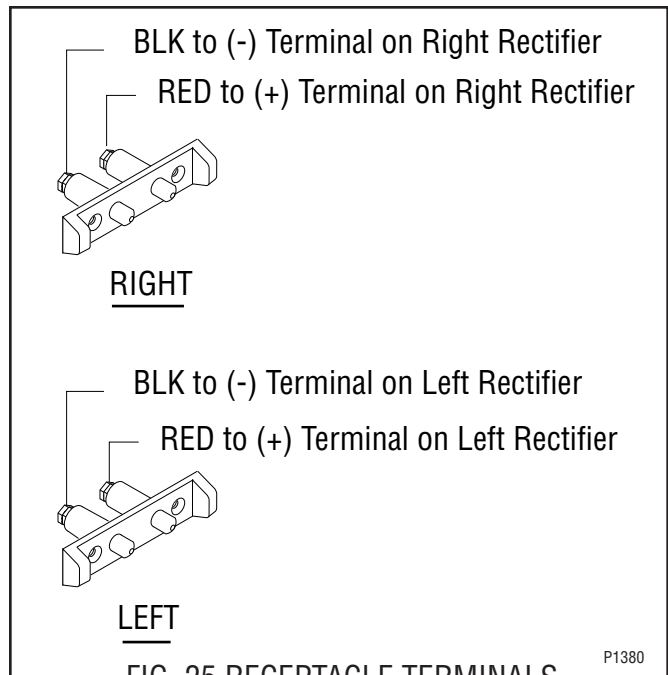

FIG. 25 RECEPTACLE TERMINALS P1380

RECTIFIERS

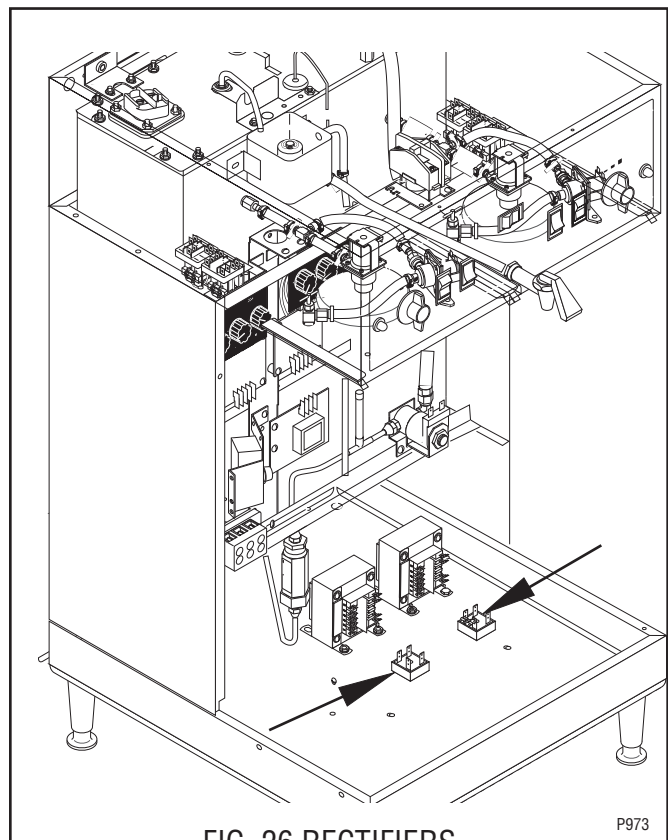

FIG. 26 RECTIFIERS P973

Location:

The rectifiers are located inside the base housing on the right side of the base plate just in front of the transformers.

SERVICE (cont.)

RECTIFIERS (cont.)

Test Procedures:

1. Disconnect the brewer from the power source;
2. Remove the red wire and the black wire from the rectifier to be tested.
3. With a voltmeter check the voltage across the (+) and (-) terminals on the rectifier. Connect the brewer to the power source. The indication must be 24 volts dc.
4. Disconnect the brewer from the power source.

If voltage is present as described, the rectifier is operating properly.

If voltage is not present as described, refer to the brewer wiring diagrams and check the brewer wiring harness.

Removal and Replacement:

1. Disconnect the wires from the rectifier.
2. Remove the #6-32 truss head screw securing the rectifier to the brew base plate.
3. Remove the rectifier and discard.
4. Install new rectifier on base plate and secure with a #6-32 truss head screw.
5. Refer to Fig. 27 when reconnecting the wires.

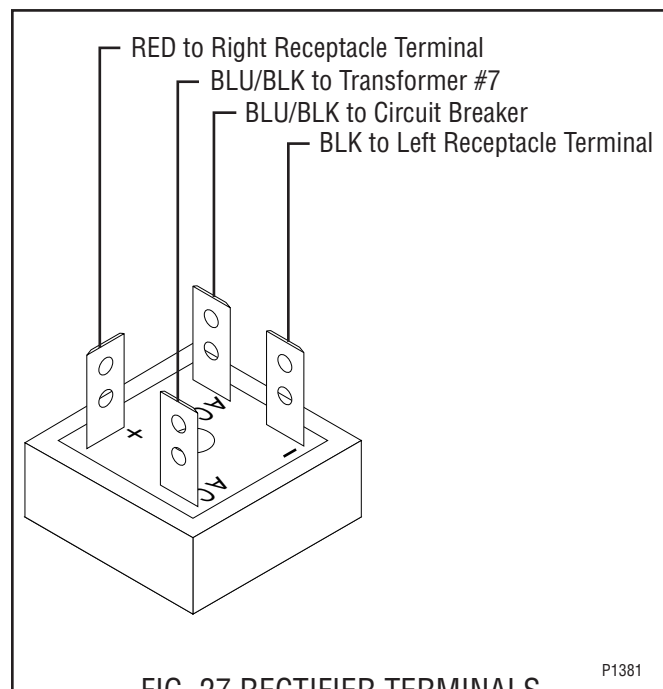

FIG. 27 RECTIFIER TERMINALS

RELAY (Brewers W/Recovery Booster)

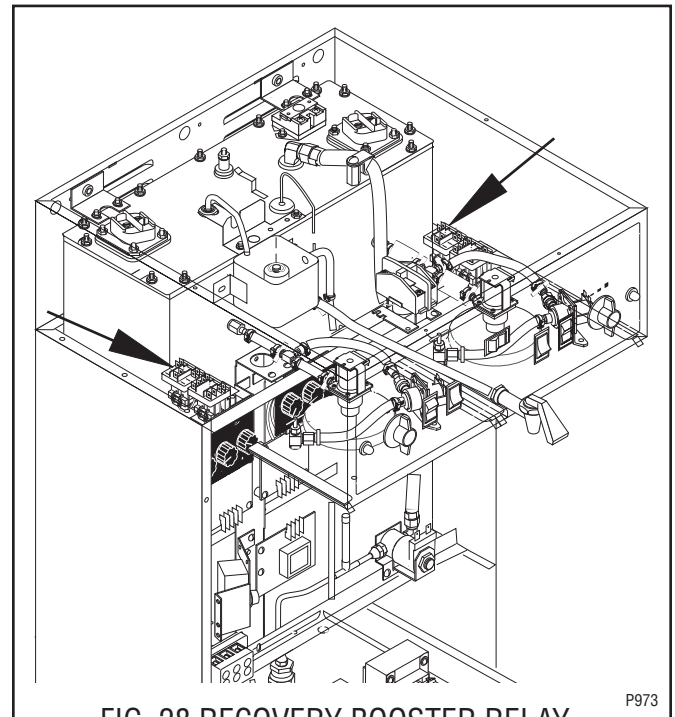

FIG. 28 RECOVERY BOOSTER RELAY

Location:

The relays are located inside the hood, the right relay is just to the right of the contactor in front of the tank and the left relay is just left of the component bracket in front of the tank.

Test Procedures:

1. Disconnect the brewer from the power source.
2. Locate the black wire on the left relay center terminal and the blue wire on the right relay center terminal.
3. Check the voltage across the black and blue wire with a voltmeter. Connect the brewer to the power source. The indication must be:
 - a.) 120 volts ac for three wire 120/208 volt models and three wire 120/240 volt models.
 - b.) 200 to 240 volts ac for two wire 200, 230 or 240 volt models.
4. Disconnect brewer from the power source.

If voltage is present as described, proceed to #5. If voltage is not present as described, refer to the wiring diagrams and check the brewer wiring harness.

5. Remove the white/green wire from the "A" terminal and white/violet wire from the "B" terminal on the right relay, the white/brown from the "A" terminal

SERVICE (cont.)

Relay (Brewers W/Recovery Booster) (cont.)

and white/red wire from "B" terminal on the left relay.

6. Check for continuity across the "A" and "B" terminals of each relay.

If continuity is present as described, reconnect the white /green wire and white/violet wire to the right relay or the white/brown and the white /red wire to the left relay and proceed to #7.

If continuity is not present as described, replace the relay(s).

7. Remove the two blue wires from terminal 5 and the red wire from terminal 7 on the right relay, the black wires from terminal 5 and the red wire from terminal 7 on the left relay.
8. Check for continuity across terminals 5 and 7 of each relay by manually closing relay contact. Continuity must not be present when contact is released.

If continuity is present as described, reconnect blue wires to terminal 5 on the right relay, the black wires to terminal 5 on the left relay and the red wire to left and right terminal 7, the relays are operating properly. If continuity is not present as described, replace the relay(s).

Removal and Replacement:

1. Remove all wires from relay terminals.
2. Remove the #6-32 truss head screw securing relay to the relay mounting bracket.
3. Remove the relay and discard.
4. Securely install the new relay to the mounting bracket using a #6-32 truss head screw.
5. Refer to Fig. 29 when reconnecting the wires.

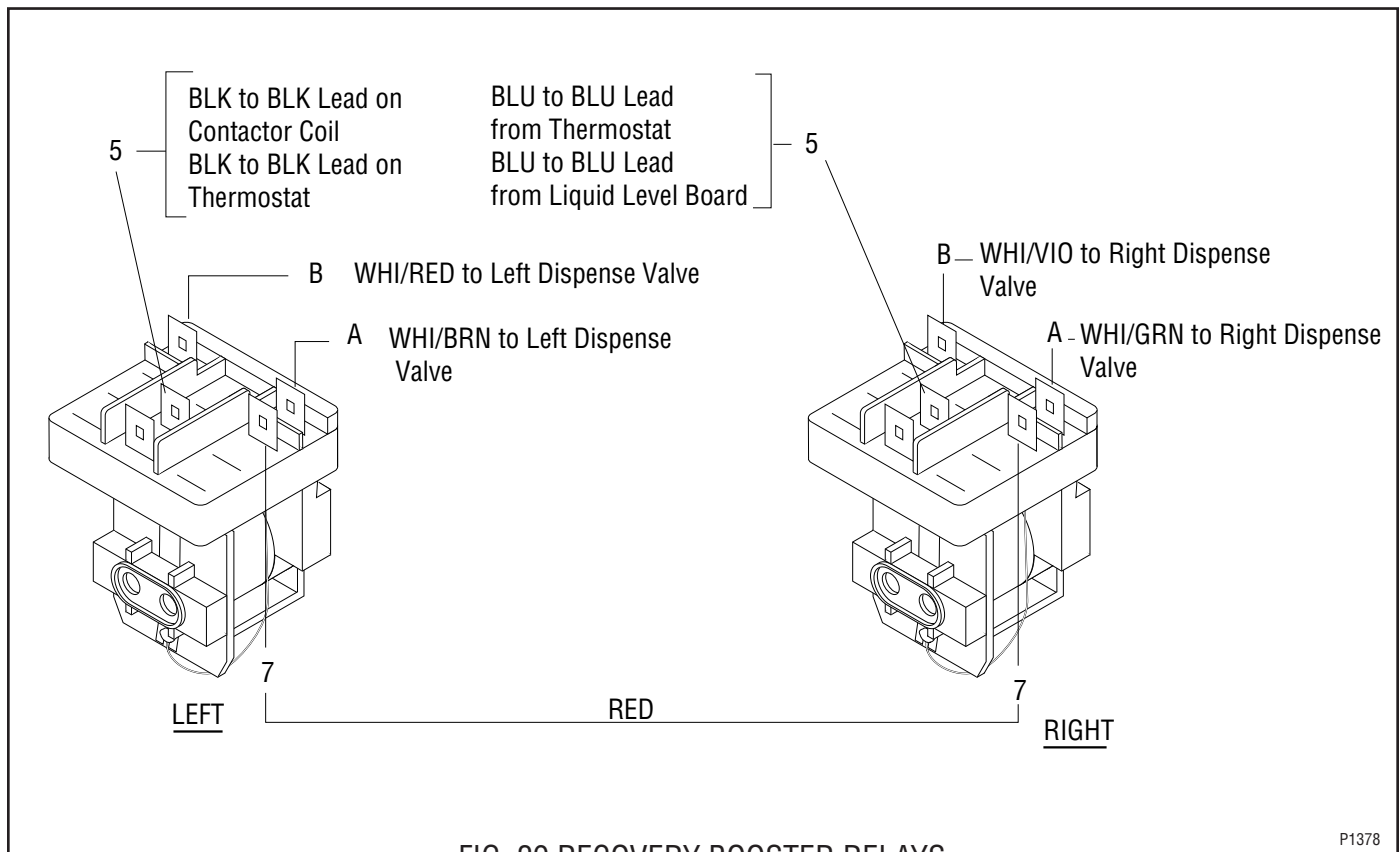

SERVICE (cont.)

RELAY (SERVER POWER)(Prior to S.N. DUAL026000)

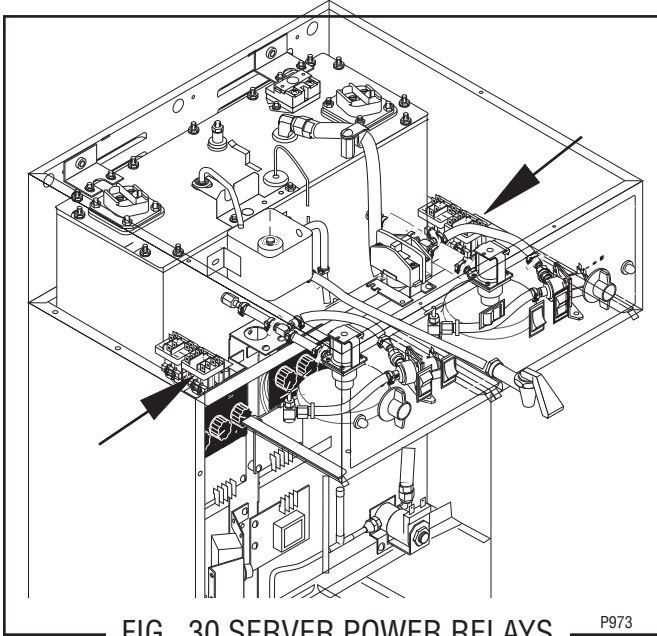

FIG. 30 SERVER POWER RELAYS

Location:

The relays are located inside the hood, the right relay just to the right of the contactor in front of the tank and left relay is just left of the component bracket in front of the tank.

NOTE: On brewers with recovery boost, the server power relays are located just in front of the recovery boost relays.

Test Procedures:

1. Disconnect the brewer from the power source.
2. Disconnect the white or red wire from terminal "B" and the green wire from the terminal "A" of the left or right server power relay coil. Check the voltage across the white or red wire and the green wire. Connect the brewer to the source. Place the ON/OFF switch in the "ON" position, press and hold the start switch. The indication must be:
 - a.) 120 volts ac for three wire 102/208 volt models and three wire 120/240 volt models.
 - b.) 200 to 240 volts ac for two wire 200, 230 or 240 volt models.
3. Disconnect the brewer from the power source.

If voltage is present as described, proceed to #4
If voltage is not present as described, refer to the wiring diagram and check the brewer wiring harness.

4. Check for continuity across the "A" and "B" terminals of the relay.

If continuity is present as described, reconnect the white or red wire to terminal "B" and the green wire to terminal "A" and proceed to #5.

If continuity is not present as described, replace the relay.

5. Disconnect the yellow wire from terminal 6 and the orange wire from terminal 9 on the left relay or the white/yellow from terminal 6 and white/orange wire from terminal 9 on the right relay.
6. Check for continuity across terminals 6 and 9 of the relay by manually closing the relay contacts. Continuity must not be present when the contacts are released.

If continuity is present as described, reconnect the yellow wire to terminal 6 and the orange wire to terminal 9 for the left relay or the white/yellow wire to terminal 6 and the white/orange wire to terminal 9 of the right relay.

7. Disconnect the black wires from terminals 1 and 7 from the left or right relay.
8. Check for continuity across terminals 1 and 7 until the contacts are manually opened and that continuity returns when the contacts are released.

If continuity was present as described, reconnect the wires to terminals 1 and 7.

If continuity was present as described in steps #6 and #8 the relay is operating properly.

If continuity is not present as described, replace the relay.

Removal and Replacement:

1. Remove all the wires from the relay terminals.
2. Remove the #6-32 screw securing the relay to the relay mounting bracket.
3. Remove and discard relay.
4. Securely install the new relay to the mounting bracket using a #6-32 screw.
5. Refer to Fig. 31 when reconnecting the wires.

SERVICE (cont.)

RELAY (SERVER POWER)(cont.)

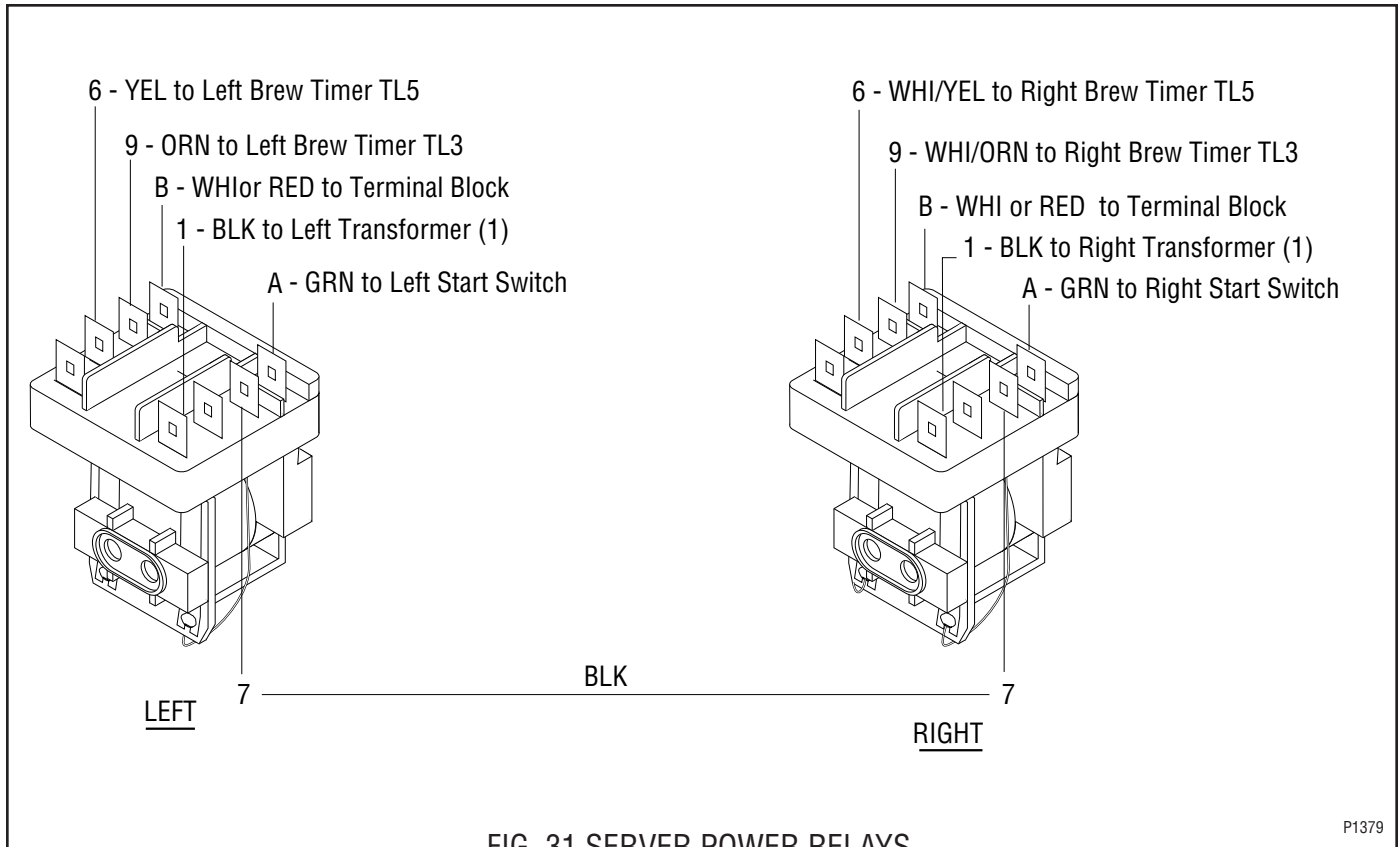

SERVICE (cont.)
SOLENOID VALVE

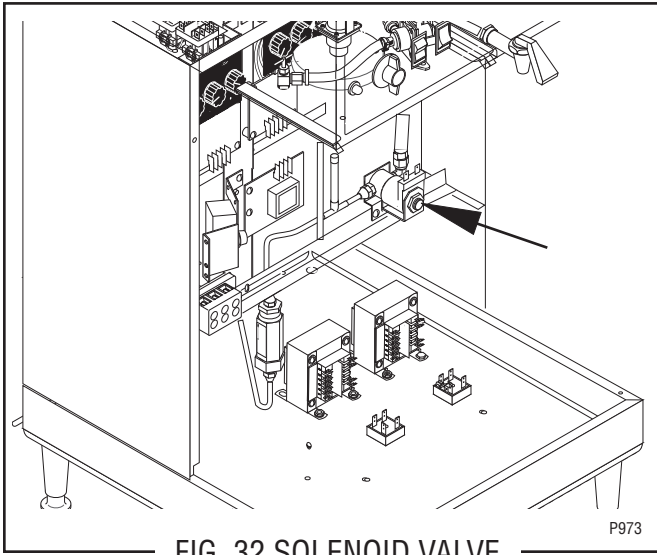

FIG. 32 SOLENOID VALVE

Location:

The solenoid valve is located inside the lower right front of the brewer.

Test Procedure:

1. Disconnect the brewer from the power source and draw 1/4 gallon of water from faucet.
2. Remove both wires from the solenoid valve coil terminals.
3. With a voltmeter check the voltage across the violet wire and white wire on 120/208 volt and 120/240 volt three wire models or violet wire and red wire on 200 volt and 240 volt two wire models. Connect the brewer to the power source. The indication must be:
 - a.) 120 volts ac for 120/208V and 120/240V three wire models.
 - b.) 200 to 240 volts ac for 200, 230 or 240V two wire models.
4. Disconnect the brewer from the power source.

If voltage is present as described, proceed to #5.
 If voltage is not present as described, refer to the wiring diagrams and check brewer wiring harness.

5. Check for continuity across the solenoid valve coil terminals.

If continuity is present as described, reconnect the white and violet wires on the 120/208 and 120/240 volt brewers or the red and violet wires on 200, 230 or 240 volt brewers.

If continuity is not present as described, replace the solenoid valve.

6. Check the solenoid valve for coil action. Connect the brewer to the power source. Listen carefully in the vicinity of the solenoid valve for a "clicking" sound after approximately 1 second, as the coil magnet attracts.
7. Disconnect the brewer from the power source.

If the sound is heard as described and water will not pass through the solenoid valve, there may be a blockage in the water line before or after the solenoid valve or, the solenoid valve may require inspection for wear, and removal of waterborne particles.

If the sound is not heard as described, replace the solenoid valve.

Removal and Replacement:

1. Remove all wires from the solenoid valve coil.
2. Turn off the water supply to the brewer.
3. Disconnect the water lines to and from the solenoid valve.
4. Remove the two #8-32 slotted head screws holding the solenoid valve and mounting bracket to the brewer trunk.
5. Lift-out the solenoid valve.
6. Remove the two #10-32 slotted head screws holding the solenoid valve to the mounting bracket.
7. Securely install the new solenoid valve to its mounting bracket.
8. Attach the solenoid valve and mounting bracket to the brewer trunk.
9. Securely fasten the water lines to and from the solenoid valve.
10. Refer to Fig. 33 when reconnecting the wires.

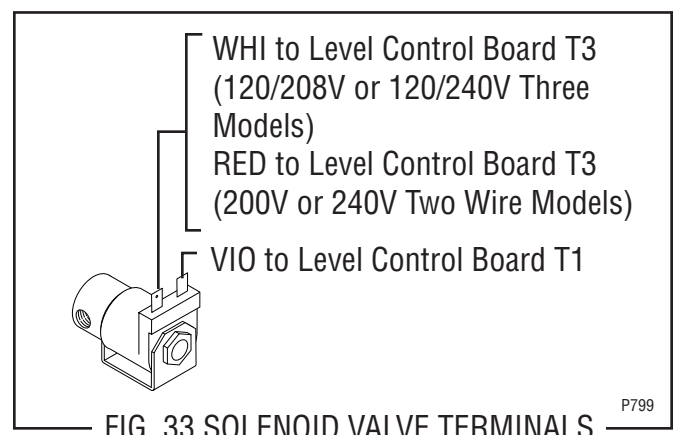

FIG. 33 SOLENOID VALVE TERMINALS

SERVICE (cont.)

START SWITCHES

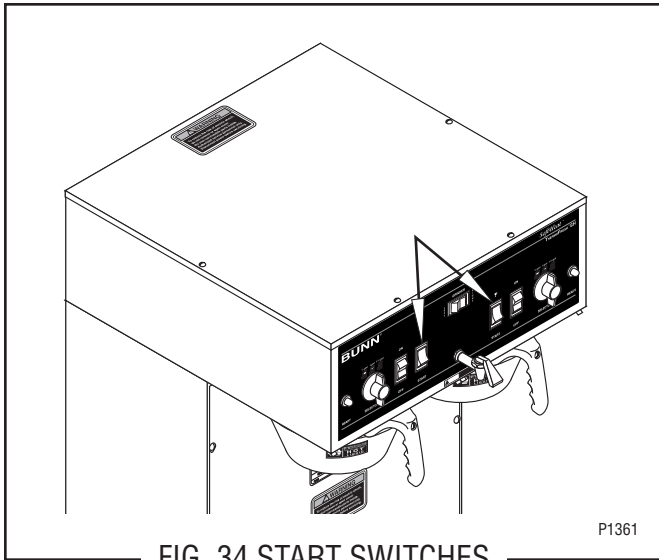

FIG. 34 START SWITCHES

Location:

The momentary start switches are located in front of hood just left and right of center.

Test Procedure:

1. Disconnect the brewer from the power source and remove the wires from both terminals of the switch.
2. Check for continuity across the two terminals on the switch when it is held in the lower position. Continuity must not be present across these terminals in the upper position.

If continuity is present as described, reconnect the wires, the switch is operating properly. If continuity is not present as described, replace the switch.

Removal and Replacement:

1. Remove all wires from the switch terminals.
2. Compress the clips inside the hood and gently push the switch through the opening.
3. Push the new switch into the opening and spread the clips to hold the switch in the hood.
4. Refer to Fig. 35 when reconnecting the wires.

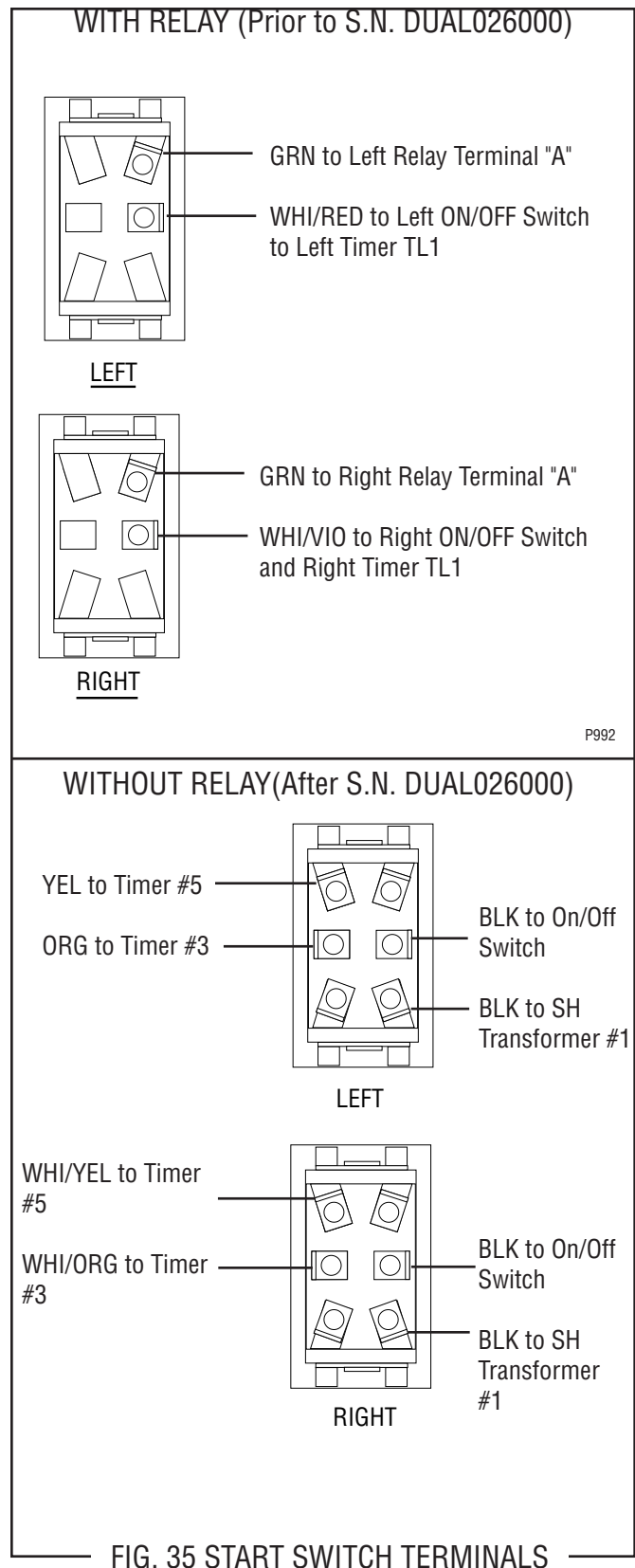

FIG. 35 START SWITCH TERMINALS

SERVICE (cont.)

TANK HEATERS

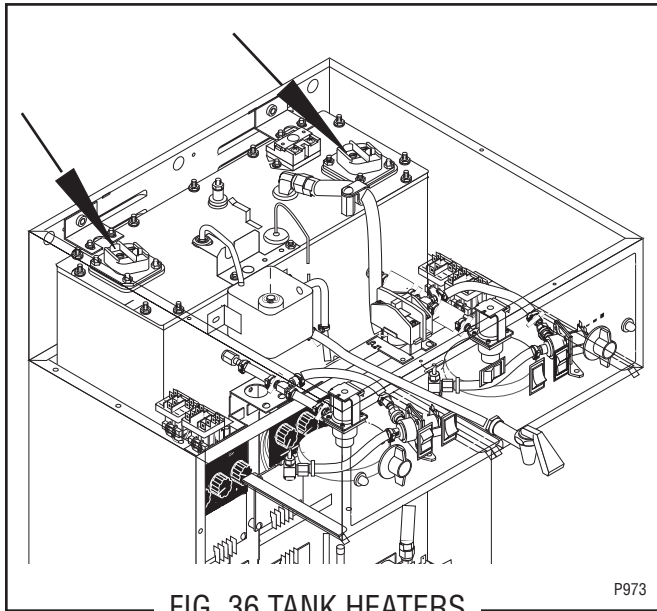

FIG. 36 TANK HEATERS

Location:

The tank heaters are located on the left and right side of the tank lid.

Test Procedure:

1. Disconnect the brewer from the power supply.
2. Check the voltage across the black and the red wires on three wire 120/208V, 120/240V or two wire 200, 230 or 240 volt models on the tank heaters. With the control thermostat turned to the "ON" position (fully clockwise), connect the brewer to the power supply and check the voltage across the wires with a voltmeter. The indication should be:
 - a.) 208 volts ac for three wire 120/208 volt models and 240 volts ac for three wire 120/240 volt models.
 - b.) 200 to 240 volts ac for two wire 200, 230 or 240 volt models.
3. Disconnect the brewer from the power supply.

If voltage is present as described, proceed to #4.
If voltage is not present as described, refer to the wiring diagrams and check the wiring harness.

4. Remove the black and red wires from the tank heaters.
5. Check for continuity across the terminals of the tank heaters.

If continuity is present as described, reconnect the wires, the tank heaters are operating properly. If continuity is not present as described, replace the tank heater(s).

NOTE - If the tank heater remains unable to heat, remove and inspect the heater for cracks in the sheath.

Removal and Replacement:

1. Remove wires from tank heater.
2. Remove the four #8-32 nuts securing tank heater to tank lid.
3. Remove tank heater and gasket.
4. Install new tank heater and gasket with four #8-32 nuts on tank lid.
5. Refer to Fig. 37 when reconnecting the wires.

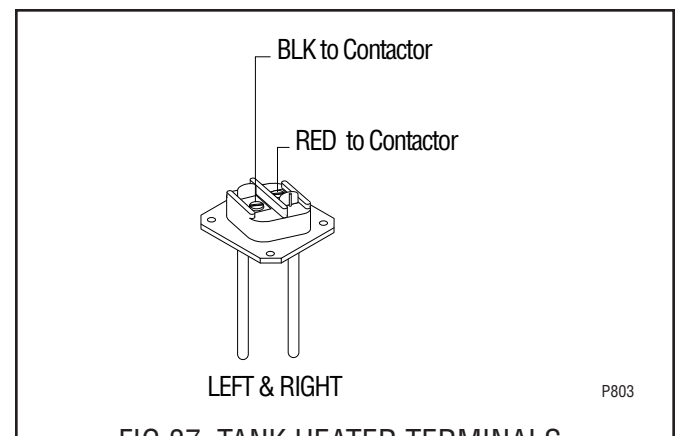

FIG. 37. TANK HEATER TERMINALS

SERVICE (cont.)

TIMERS (Early Models)

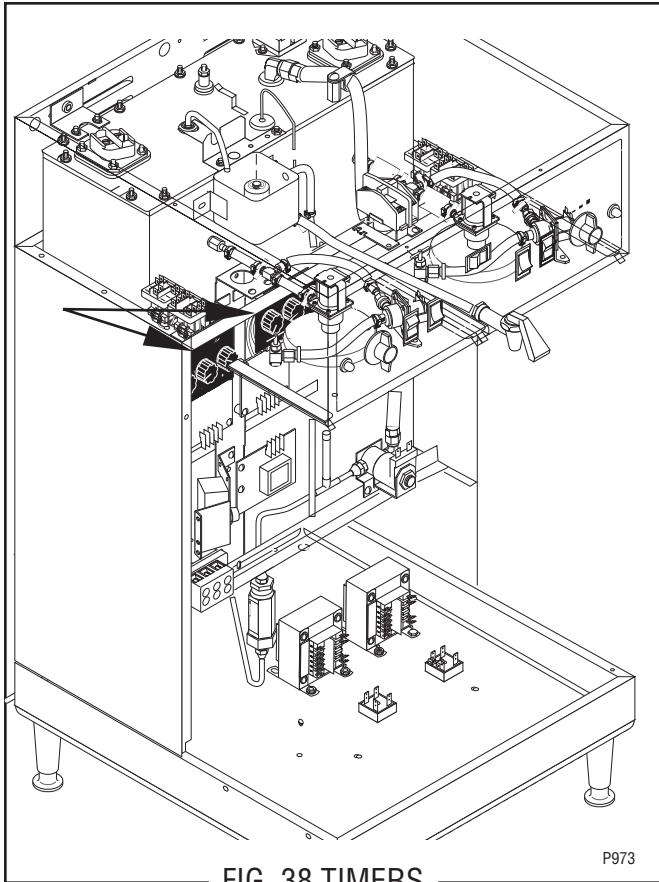

FIG. 38 TIMERS

Location:

___ The timers are located inside the left front of the brewer on the upper part of the component bracket.

Test Procedures:

1. Disconnect the brewer from the power source.
2. Disconnect the wires from the timer terminals TL3, TL4 and TL5 and rotate the dial(s) fully counter-clockwise.
3. With a voltmeter check the voltage across terminals TL1 and TL2 when the "ON/OFF" switch is in the "ON" position. Connect the brewer to the power source. The indication must be:
 - a.) 120 volts ac for three wire 120/208 volt models and three wire 120/240 volt models.
 - b.) 200 to 240 volts ac for two wire 200, 230 or 240 volt models.
4. Disconnect the brewer from the power source.

If voltage is present as described for the right timer reconnect the white/orange wire to TL3, white/green to TL4 and white/yellow to TL5. For the left timer re-

connect the orange wire to TL3, white/brown to TL4, and yellow to TL5 then proceed to #5.

If voltage is not present as described, refer to the wiring diagrams and check the brewer wiring harness.

5. Place a server under the funnel and select 1/2 gallon position on the selector switch.
6. Check the voltage across terminals TL1 and TL4 with a voltmeter when the "ON/OFF" switch is in the "ON" position. Connect the brewer to the power source and press the start switch. The indication must be:
 - a.) 120 volts ac for three wire 120/208 volt models and three wire 120/240 volt models for approximately 20 seconds for 1/2 gallon batch.
 - b.) 200 to 240 volts ac for two wire 200, 230 or 240 volt models for approximately 20 seconds for 1/2 gallon batch.
7. Place a 1-3/4 gallon server under the funnel. Select a 1 gallon batch and repeat #6. The voltage indication should remain for approximately 40 seconds.
8. Select a 1-1/2 or 1-3/4 gallon batch and repeat #6. The indication should remain approximately 1 minute.

If voltage indications were as described the timer is operating properly.

If voltage indications were other than described, replace the timer.

Removal and Replacement:

1. Remove all wires from the timer.
2. Remove the four #6-32 slotted head screws holding circuit board and dial plate on to the component mounting bracket.
3. Remove circuit board, nylon spacers and dial plate.
4. Install new dial plate and circuit board with nylon spacers to component mounting bracket.
5. Refer to Fig. 39 when reconnecting wires.
6. Adjust timer dials as required.

SERVICE (cont.)

Timers (Early Models)(cont.)

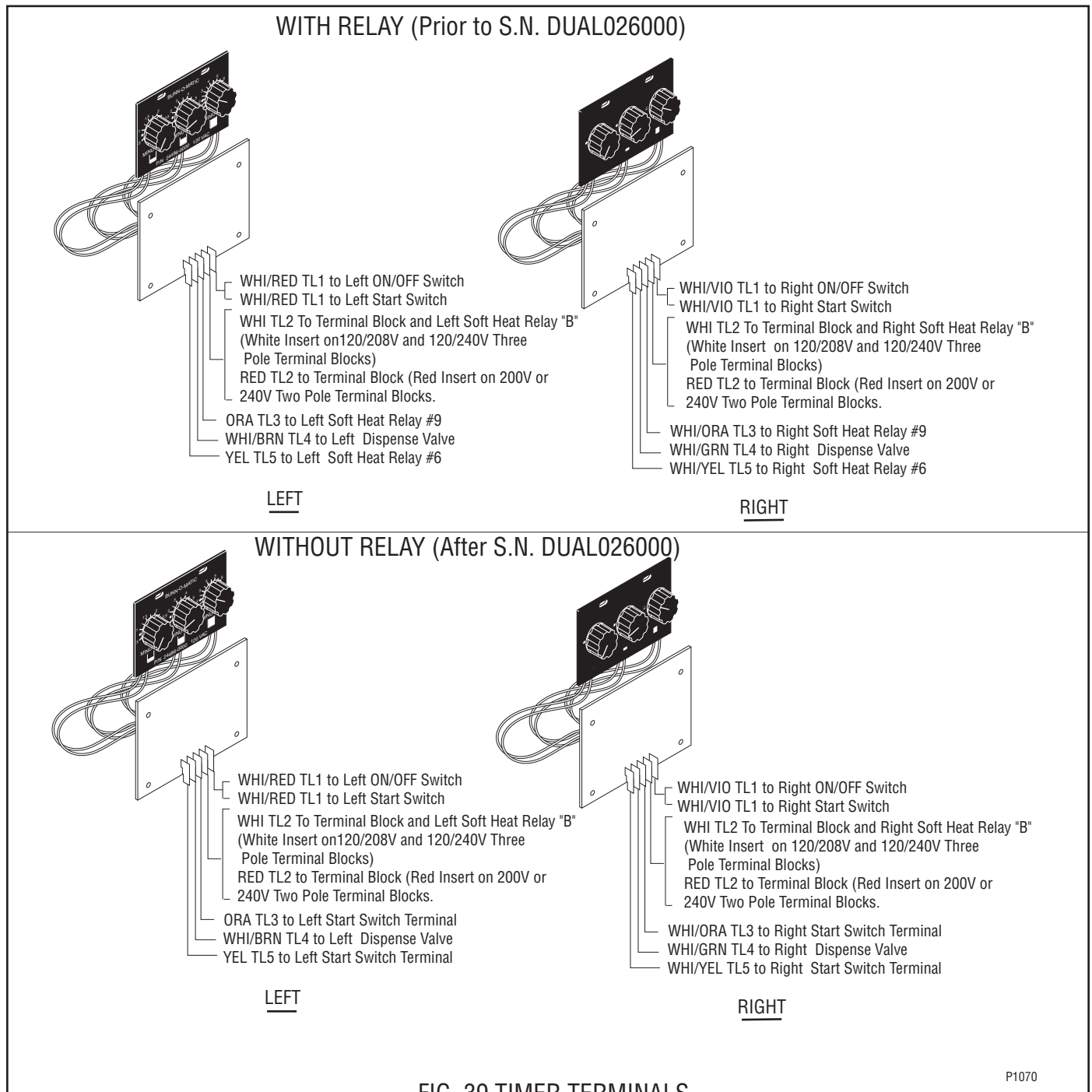
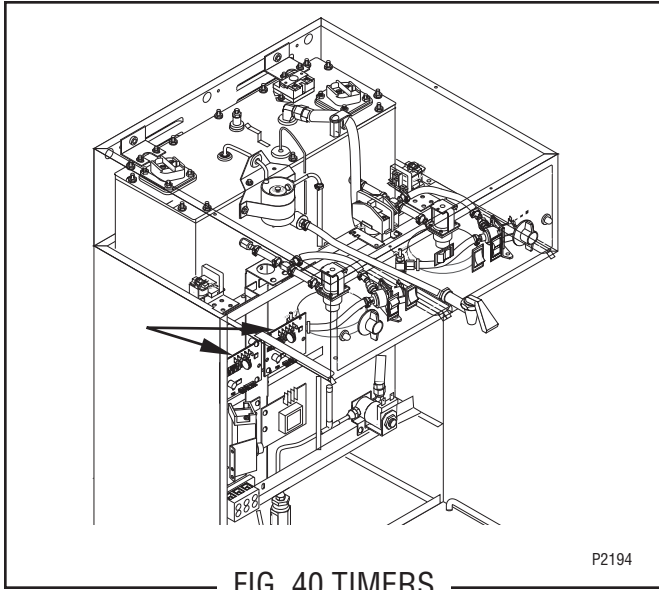

FIG. 39 TIMER TERMINALS

P1070

SERVICE (cont.)

TIMERS (Late Models)



Location:

The timers are located inside the left front of the brewer on the upper part of the component bracket.

Test Procedures:

NOTE: Do not remove or install wires while timer board is installed. Pressure applied to one side may cause damage to the board.

1. Disconnect the brewer from the power source and remove the front panel.
2. Check the voltage across terminals TL1 and TL2 with a voltmeter when the "ON/OFF" switch is in the "ON" position. Connect the brewer to the power source. The indication must be:
 - a.) 120 volts ac for two wire 120 volt models, three wire 120/208 volt models and three wire 120/240 volt models.
 - b.) 200 to 240 volts ac for two wire 200 or 240 volt models.
3. Disconnect the brewer from the power source.

If voltage is present as described, proceed to #4.
If voltage is not present as described, refer to the wiring diagrams and check the brewer wiring harness.

4. Disconnect the ORA or WHI/ORA wire from terminal TL3 and the YEL or WHI/YEL wire from terminal TL5. Check for continuity across the two wires when the start switch is pressed to the "START" position.

If continuity is present as described, reconnect the wires and proceed to #5.

If continuity is not present as described, refer to the wiring diagrams and check the brewer wiring harness.

5. Check the voltage across terminals TL1 and TL4 with a voltmeter when the "ON/OFF" switch is in the "ON" position. Connect the brewer to the power source. The indication must be zero volts.

If voltage indications are other than described, disconnect the brewer from the power source and replace the timer.

6. Check the voltage across terminals TL1 and TL4 with a voltmeter when the "ON/OFF" switch is in the "ON" position. Connect the brewer to the power source and press the start switch. The indication must be:
 - a.) 120 volts ac for two wire 120 volt models, three wire 120/208 volt models and three wire 120/240 volt models.
 - b.) 200 to 240 volts ac for two wire 200 or 240 volt models.

If voltage indications are other than described, disconnect the brewer from the power source and replace the timer.

7. Remove the test equipment and connect all wires as described below.

Removal and Replacement:

NOTE: Do not remove or install wires while timer board is installed. Pressure applied to one side may cause damage to the board.

1. Remove the six #6-32 screws securing circuit board to component mounting bracket.
2. Remove circuit board and nylon spacers.
3. Remove all wires from the timer.
4. Attach all wires to the replacement timer board prior to installation to the component mounting bracket. Refer to FIG. 41 when reconnecting the wires.
5. Install new circuit board with nylon spacers to component mounting bracket using four #6-32 screws.
6. Adjust the timer as described below.

SERVICE (cont.)

TIMERS (Late Models)(cont.)

Timer Setting:

NOTE: Check that the brewer is connected to water supply, the tank is properly filled, and a funnel and server are in place, prior to setting or modifying volumes.

NOTE: All volume settings must be done with the sprayhead installed.

1. **Modifying brew volumes.** To modify a brew volume, first check that the SET/LOCK switch is in the "SET" position on the circuit board.

To increase a brew volume, place the ON/OFF switch in the "ON" position, press and hold the START switch until three clicks are heard. Release the switch (Failure to release the switch within two seconds after the third click causes the volume setting to be aborted and previous volume setting will remain in memory) and press it again one or more times. Each time the switch is pressed, two seconds are added to the brew time period. Allow the brew cycle to finish in order to verify that the desired volume has been achieved.

To decrease a brew volume, place the ON/OFF switch in the "ON" position, press and release the START switch once for every two-second interval to be removed from the total brew time period; then immediately press and hold down the START switch until three clicks are heard. Release the switch. (Failure to release the switch within two seconds after the third click causes the volume setting to be aborted and previous volume setting will remain in memory). Allow the brew cycle to finish in order to verify that the desired volume has been achieved.

2. **Setting brew volumes.** To set a brew volume, first check that the SET/LOCK switch is in the "SET" position on the circuit board. Place the ON/OFF switch in the "ON" position, press and hold the START switch until three distinct clicks are heard and then release the switch. (Failure to release the switch within two seconds after the third click causes the volume setting to be aborted and previous volume setting will remain in memory). View the level of the liquid being dispensed. When

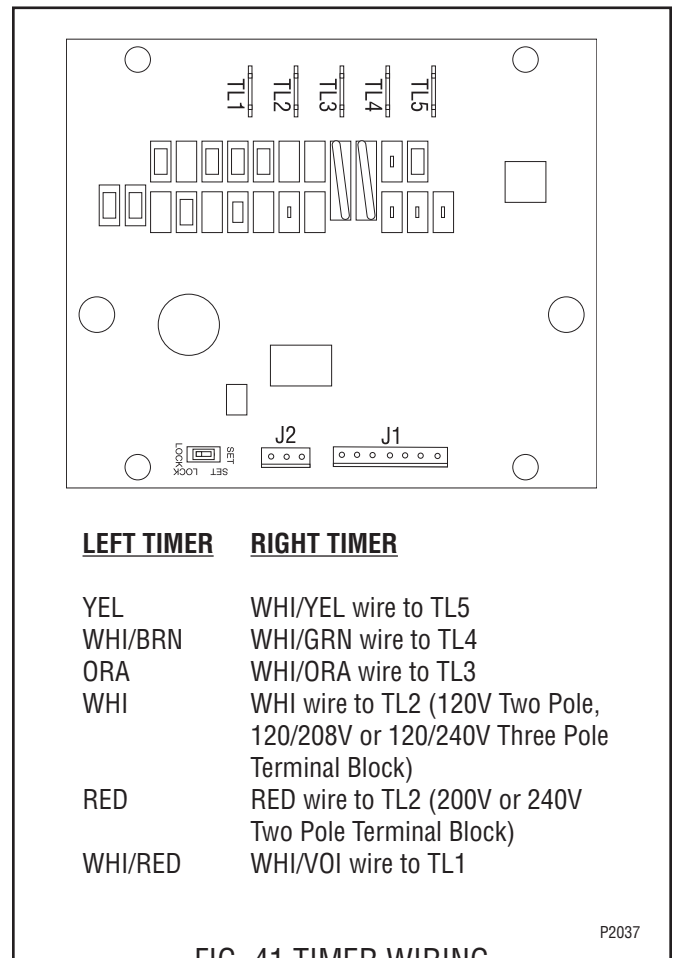

FIG. 41 TIMER WIRING

the desired level is reached, turn the ON/OFF switch to "OFF". **NOTE:** Several ounces of water will continue to syphon from the tank after turning the switch "OFF". The brewer remembers this volume and will continue to brew batches of this size until the volume setting procedure is repeated.

NOTE: When brewing coffee, volumes will decrease due to absorption by the coffee grounds.

3. **Setting programming disable feature.** If it becomes necessary to prevent anyone from changing brew time once programmed, you can set the SET/LOCK switch to the "LOCK" position. This will prevent any further programming.

SERVICE (cont.)

TRANSFORMERS

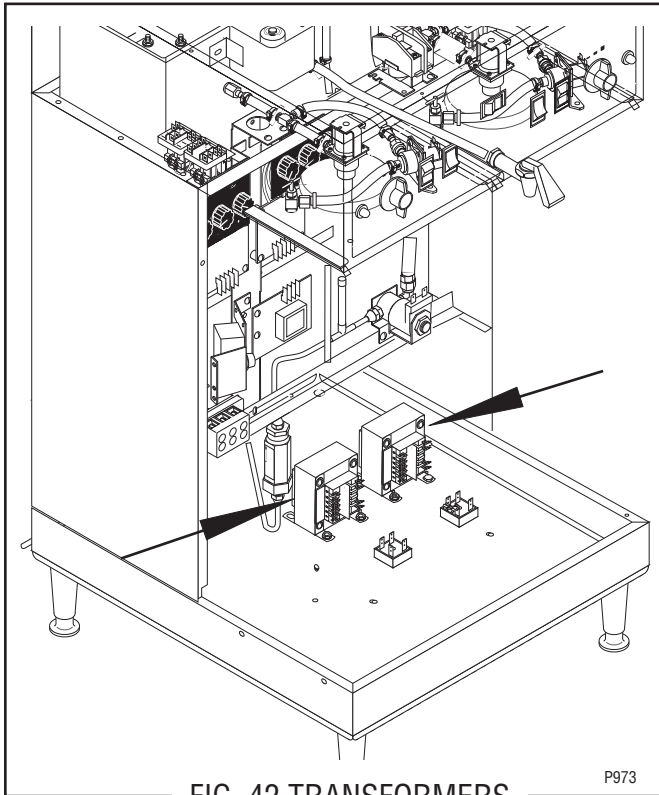

Location:

The transformers are located in the brewer base on the right center of the base plate.

Test Procedures:

1. Disconnect the brewer from the power source.
2. Disconnect the black wire from terminal #1 (from the server relay) and the white or red wire from terminal # 6.
3. With a voltmeter check the voltage across the black and white wire. Connect the brewer to the power supply. The indication must be:
 - a.) 120 volts ac for three wire 120/208 volt models and three wire 120/240 volt models.
 - b.) 200 to 240 volts ac for two wire 200, 230 or 240 volt models.
4. Disconnect the brewer from the power supply.

If voltage is present as described reconnect the wires and proceed to #5.

If voltage is not present as described, refer to the wiring diagrams and check the brewer wiring harness.

5. Disconnect the blue/black wires from terminals #7 and #12 on the transformer.
6. With a voltmeter check the voltage across the blue/black wires. Connect the brewer to the power source. The indication must be 24 volts ac.

If voltage is present as described the transformer is operating properly.

If voltage is not present as described, replace the transformer.

Removal and Replacement:

1. Disconnect all the wires from the transformer that is to be replaced.
2. Remove the two #6-32 screws and the two #6-32 keps nuts securing the transformer to the brewer base plate.
3. Remove transformer and discard.
4. Install new transformer on the brewer base plate securing with two #6-32 screws and two #6-32 keps nuts.
5. Refer to Fig. 43 to reconnect the wires.

SERVICE (cont.)

TRANSFORMERS (cont.)

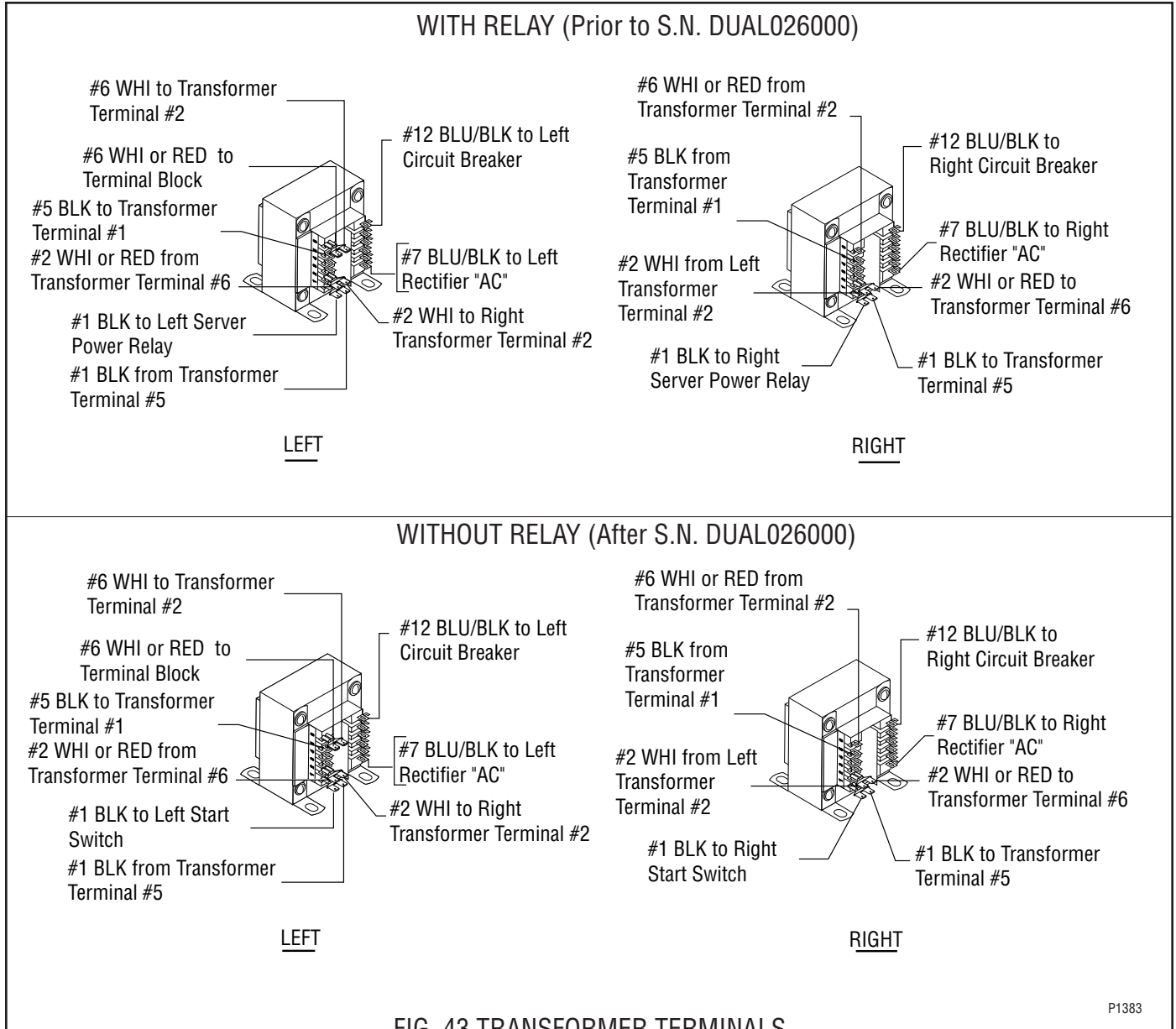

SERVICE (cont.)

MAIN ON/OFF SWITCH

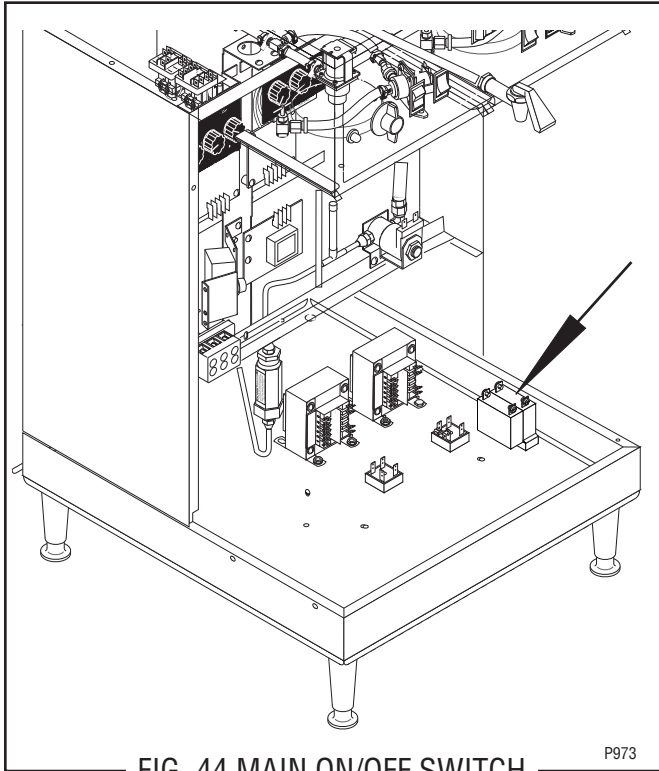

FIG. 44 MAIN ON/OFF SWITCH

Location:

The MAIN ON/OFF switch is located in the base housing behind the right front leg.

Test Procedure:

1. Disconnect the brewer from the power source.
2. Remove the red wires from the terminals.
3. Check the voltage across the red wires with a voltmeter. Connect the brewer to the power source. The indication must be 120 volts ac.
4. Disconnect the brewer from the power source.

If voltage is present as described, reconnect the red wires, and repeat steps 2 and 3 for the black wires. If voltage is not present as described, refer to the *Wiring Diagrams* and check the brewer wiring harness.

5. With the red and black wires removed, check for continuity across the right terminals and across the left terminals with switch in the "ON" position. Continuity must not be present when switch is in the "OFF" position.

If continuity is present as described, reconnect the red and black wires to the terminals.

If continuity is not present as described, replace the switch.

Removal and Installation:

1. Disconnect the wires from the switch terminals.
2. Remove the two screws securing the switch to the base plate from the bottom side of the brewer.
3. Position the new switch into the opening in the base plate and secure with the two mounting screws.
4. Refer to Fig. 45 when reconnecting the wires.

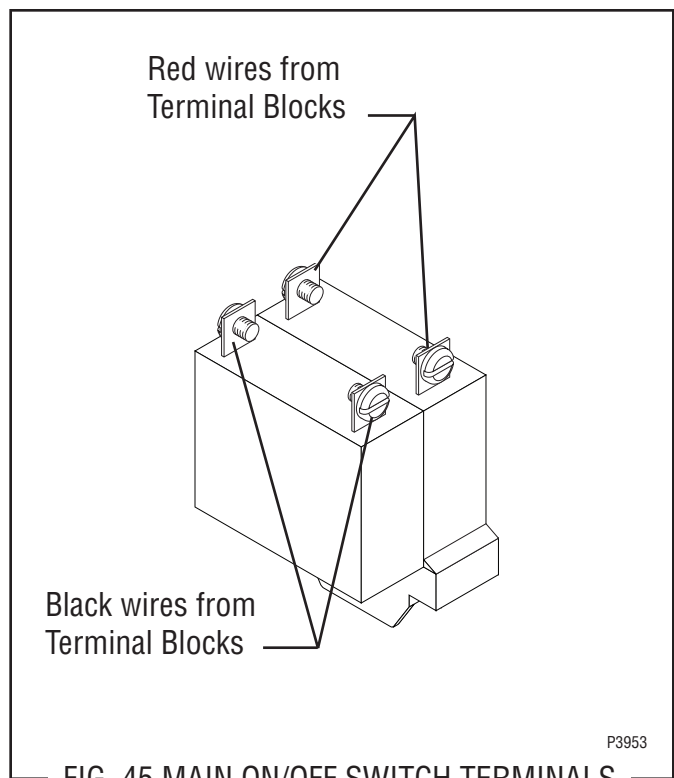
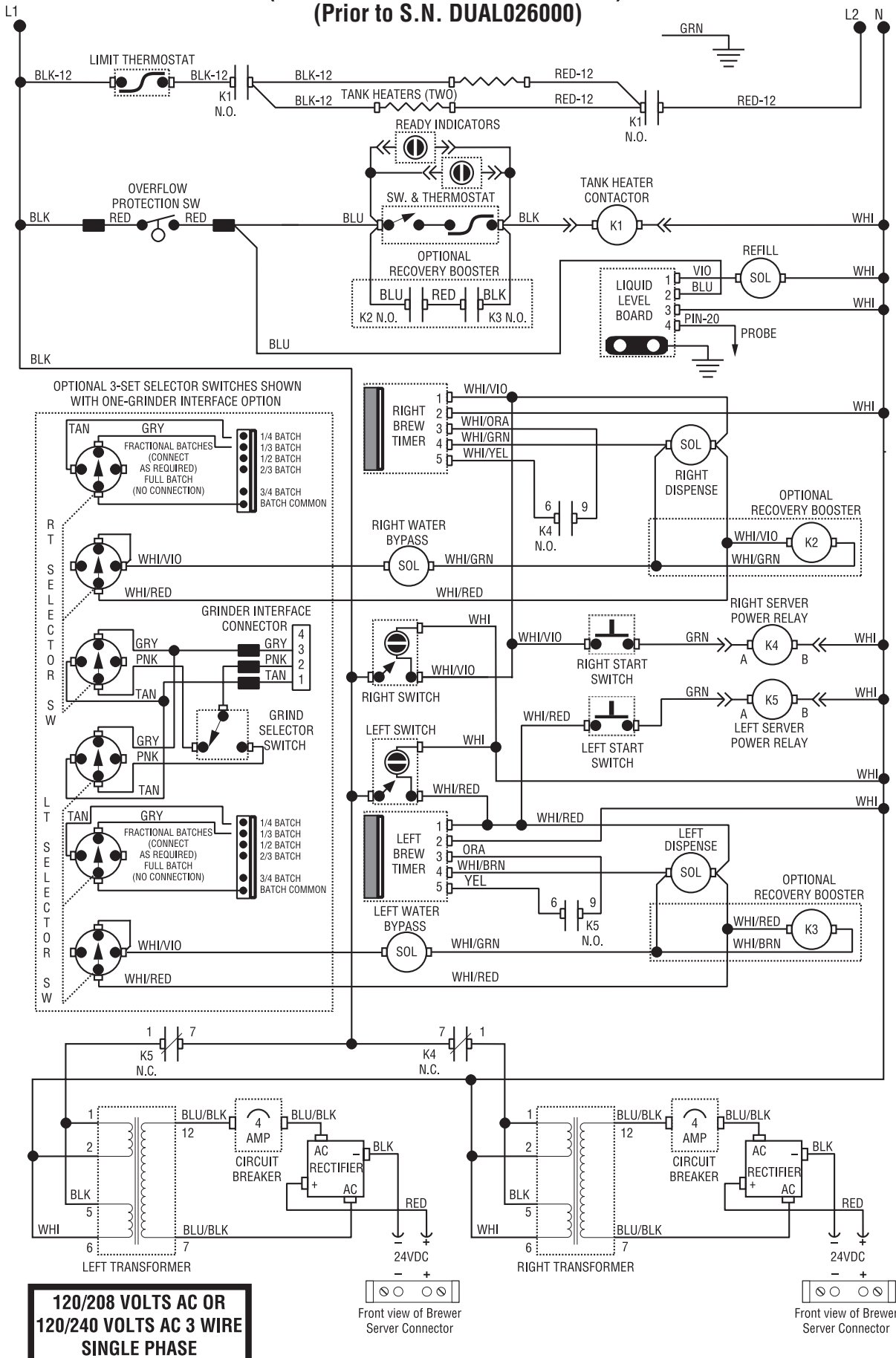
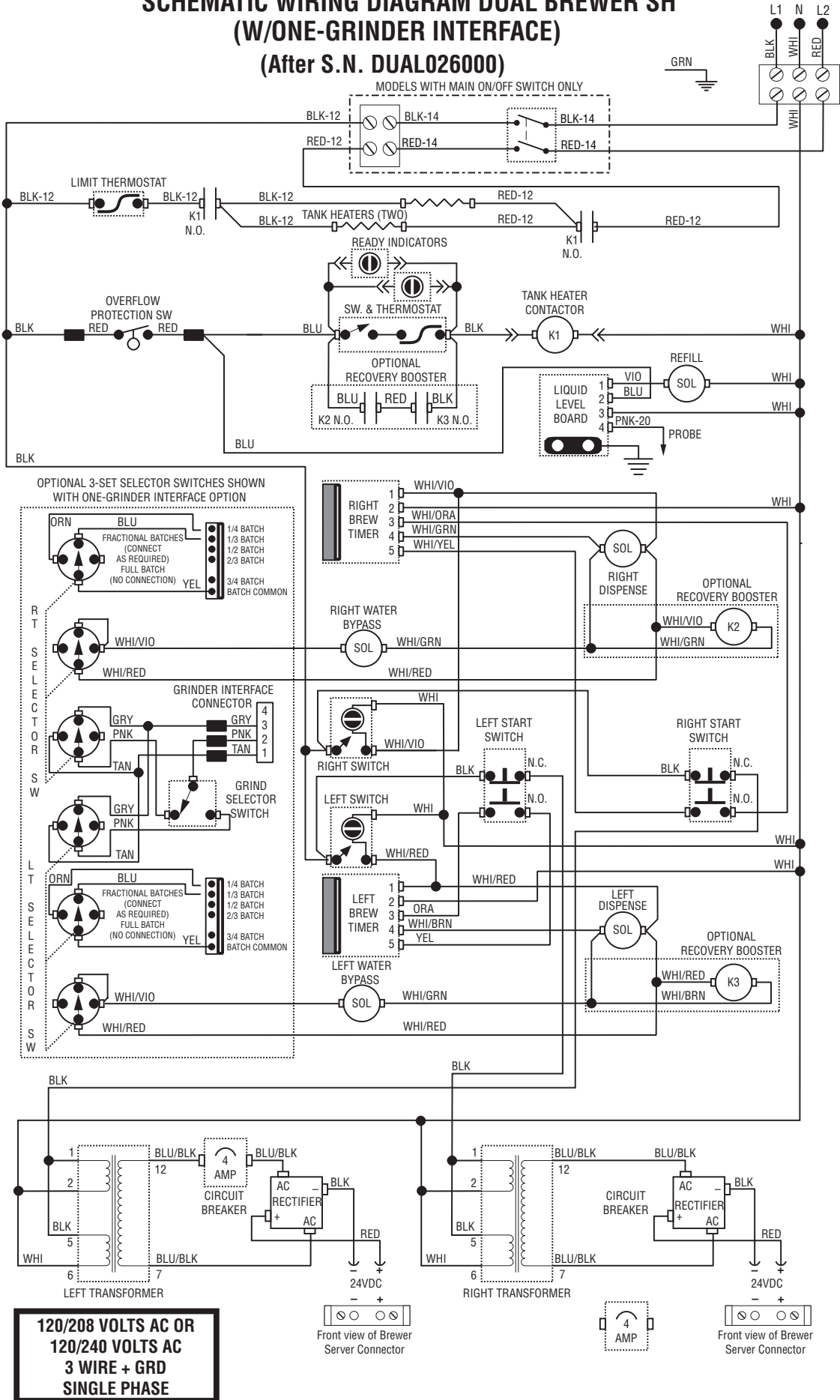

FIG. 45 MAIN ON/OFF SWITCH TERMINALS

SCHEMATIC WIRING DIAGRAM DUAL BREWER SH (W/ONE-GRINDER INTERFACE) (Prior to S.N. DUAL026000)



SCHEMATIC WIRING DIAGRAM DUAL BREWER SH (W/ONE-GRINDER INTERFACE) (After S.N. DUAL026000)



SCHEMATIC WIRING DIAGRAM DUAL SH, 230V CE

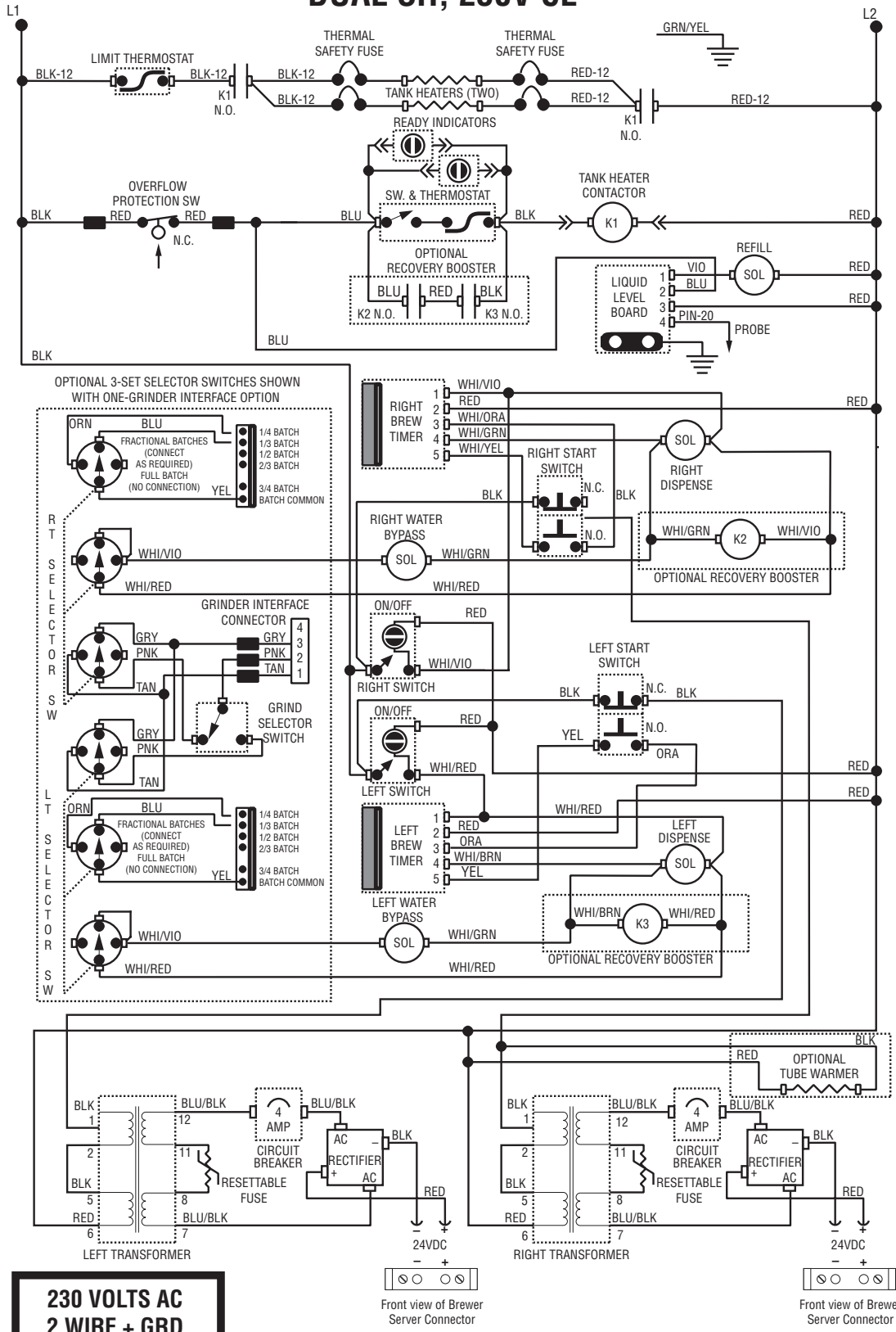

**230 VOLTS AC
2 WIRE + GRD
SINGLE PHASE**

Front view of Brewer Server Connector

Front view of Brewer Server Connector

DUAL SH BREWER W/DIGITAL BREWER CONTROL SCHEMATIC WIRING DIAGRAM

